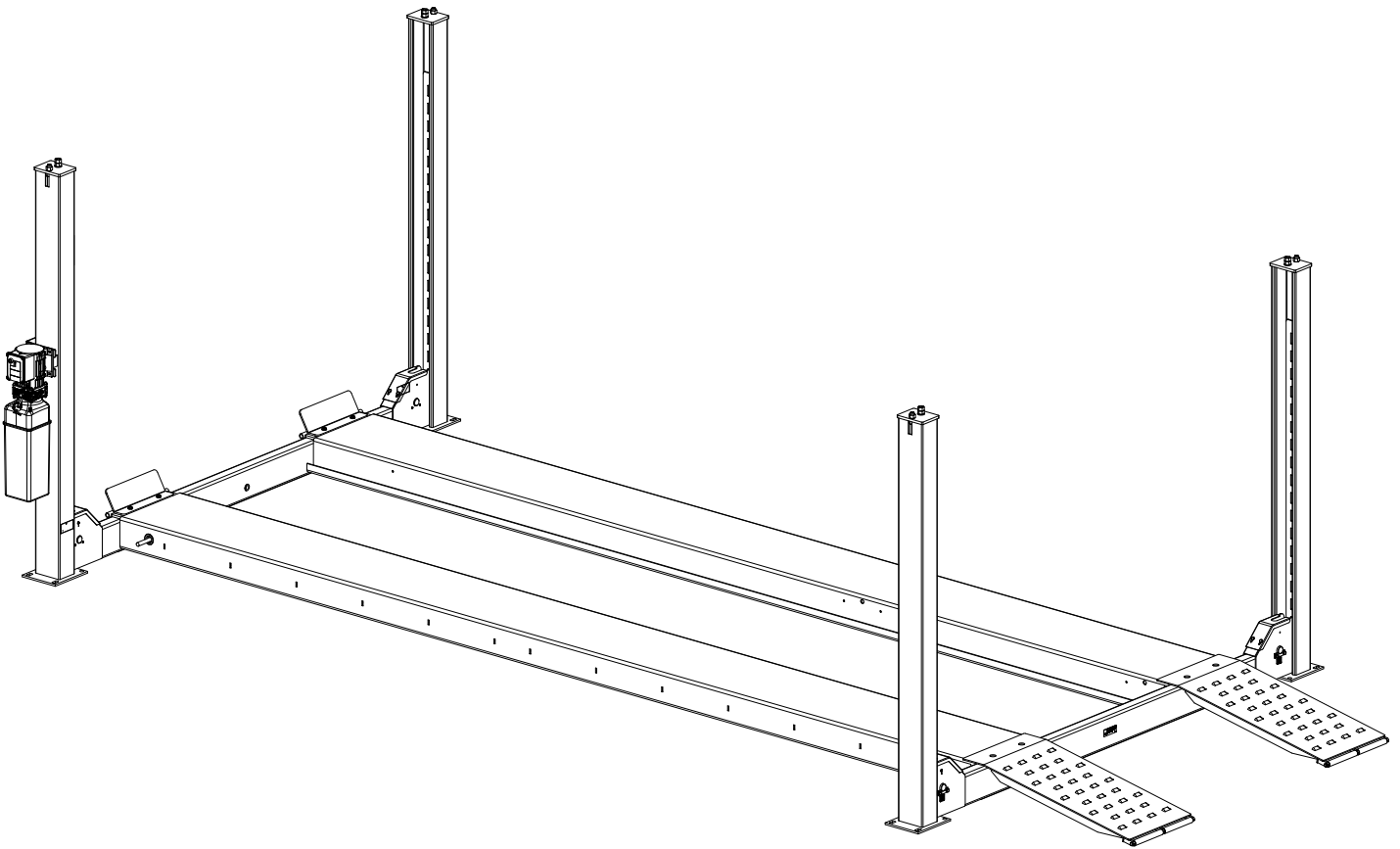


**Four Post Surface Mounted Lift**  
**Capacity 14,000 lbs. (6,350 kg.) (7,000 lbs. (3,175 kg.) per axle)**



# INSTALLATION INSTRUCTION

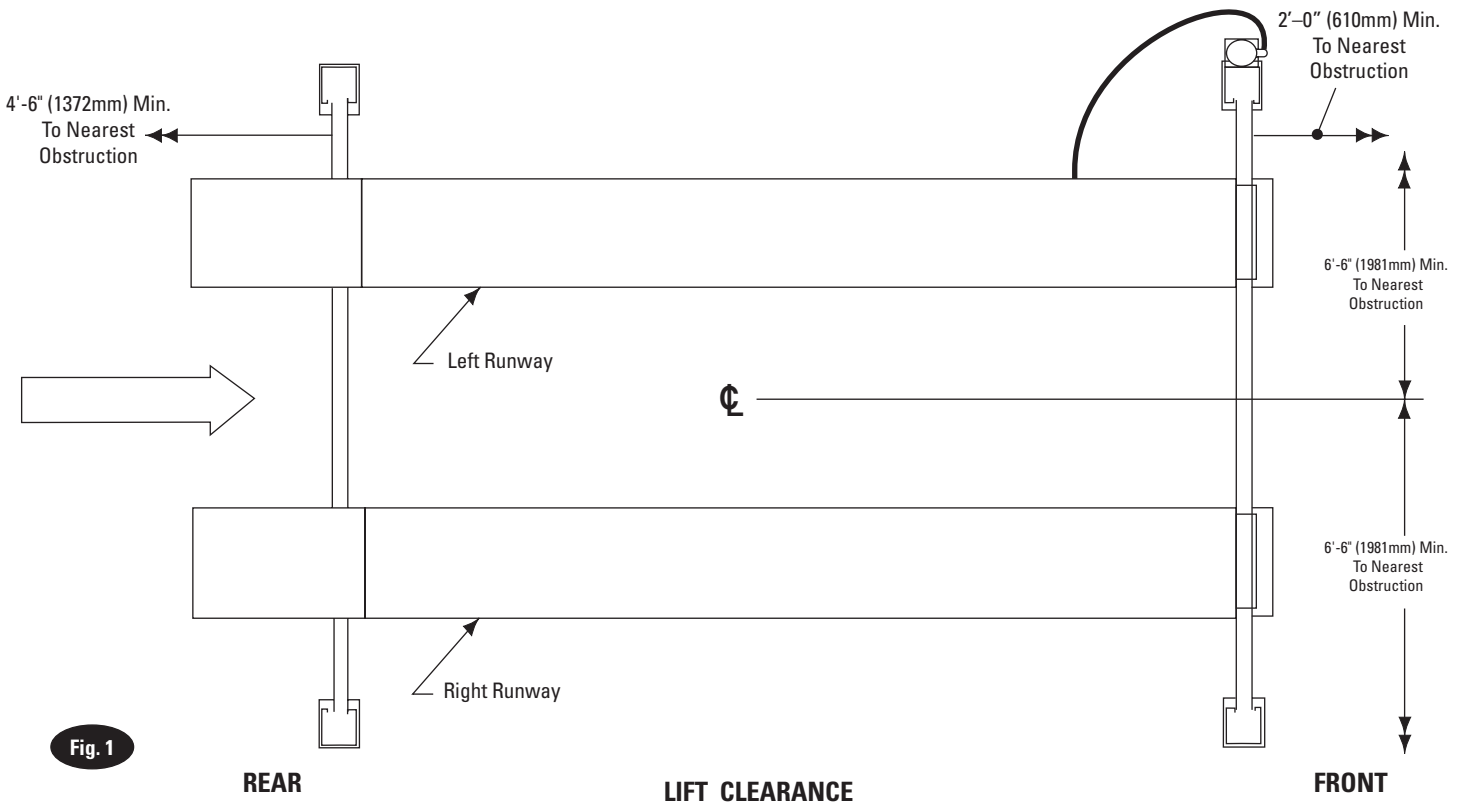


Fig. 1

**Read and understand these instructions completely before proceeding with lift installation.**

**1. Lift Location:** Use architects plan when available to locate lift. Fig. 1 shows dimensions of a typical bay layout. For power unit at right front, rotate lift 180°, leaving ramp/chocks and wheel stops in original position. Lift floor area should be level.

**⚠ WARNING** DO NOT install on asphalt or other similar unstable surface. Columns are supported only by anchors in floor.

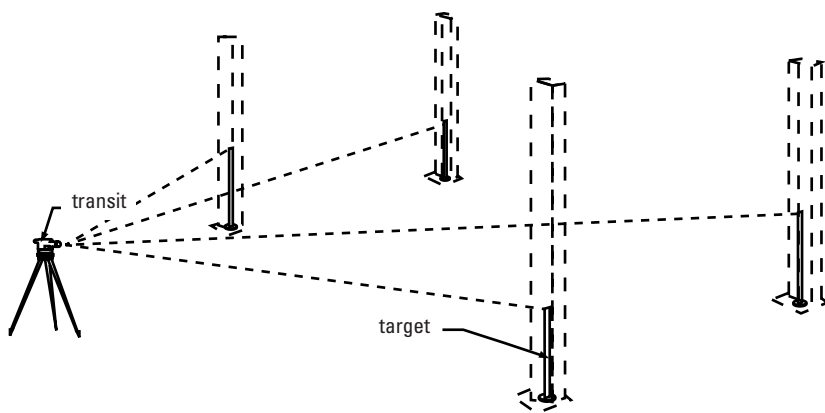
**2.** Ceiling or overhead clearance must be 92" (2337mm) plus height of tallest vehicle.

**3. Estimating Column Shim requirements:**

In the following section, the terms "highest" and "lowest" refer to elevation of floor.

- A. Mark locations where lift columns will be positioned in bay.
- B. Place target on floor at column positions (NOT on column base plates) and record readings, Fig. 2.
- C. Find the highest of the four locations. Find the difference between the reading at each of the remaining three columns and the highest reading.
- D. The difference is the estimated amount of shim thickness needed at each column.

**Note:** Maximum shim thickness is 1/2" (13mm) per column using shims and anchors provided with lift. Shim thickness of 2" (51mm) is possible by using optional shim kit #FC5393. Contact your authorized Parts Distributor for ordering information.



**Note:** Target is positioned on floor at planned column positions (NOT on column base plates).

Dimension at highest position minus other position = shim thickness required

Fig. 2

**COLUMN SHIM ESTIMATES**

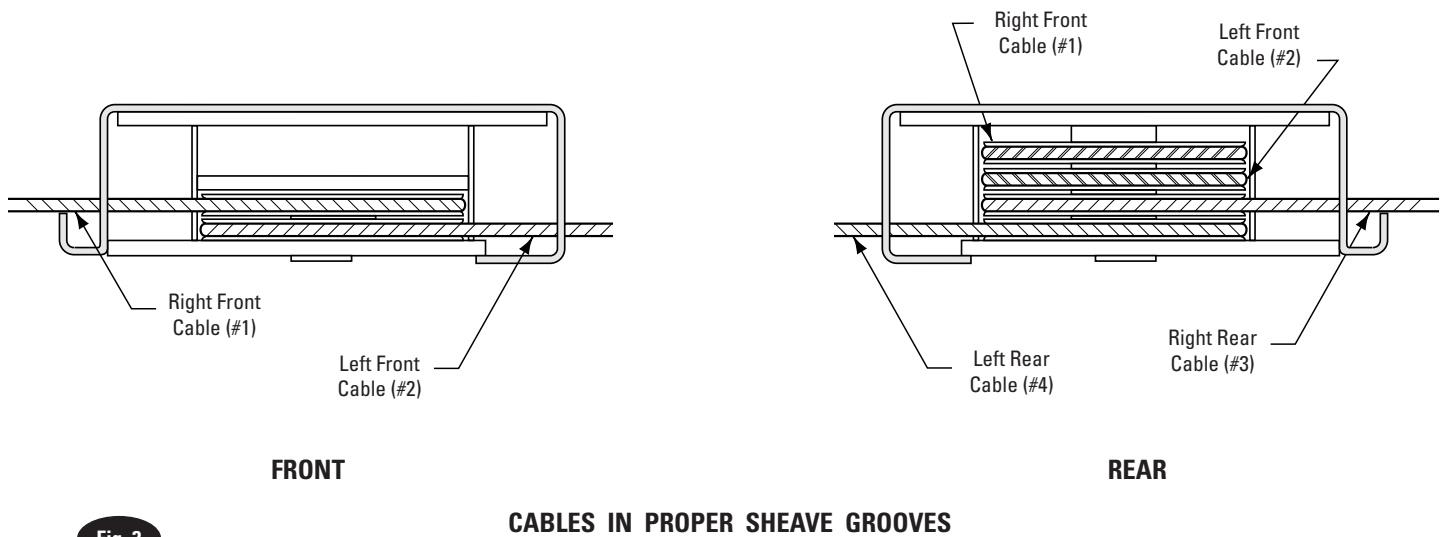


Fig. 3

CABLES IN PROPER SHEAVE GROOVES

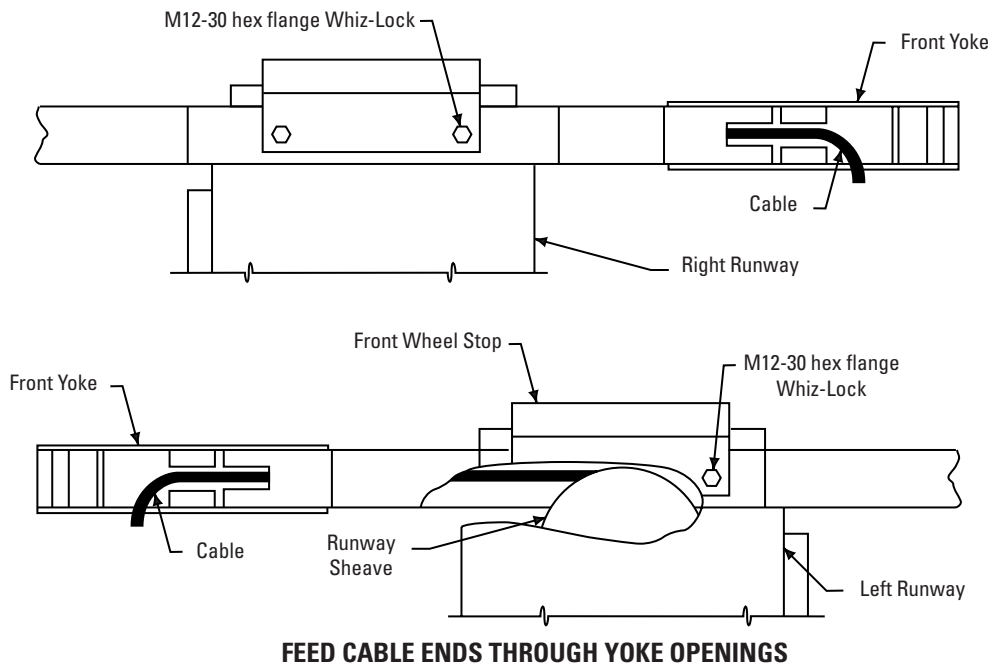


Fig. 4

FEED CABLE ENDS THROUGH YOKE OPENINGS

#### 4. Runway and Yoke Tube Assembly:

- A. Determine direction of approach in bay.
- B. Position left runway in bay with hydraulic cylinder hose connection to front of bay. Cables and sheaves are pre-assembled in runway. Runway needs to be up off floor so shipping restraints can be removed from cable ends, air and hydraulic lines, and cylinder rod. Pull cable ends, air, and hydraulic lines out for assembly. Make sure cables are in proper sheave grooves, Fig. 3.
- C. Position front and rear yokes at respective ends of runway, Fig. 1. The opening in the side of the yokes should be lined up with the cable sheaves in the runway ends. Feed cable ends through yoke openings, Fig. 4. Do not assemble sheaves in yoke ends at this time.

#### 5. Runway and Wheel Stop Attachment:

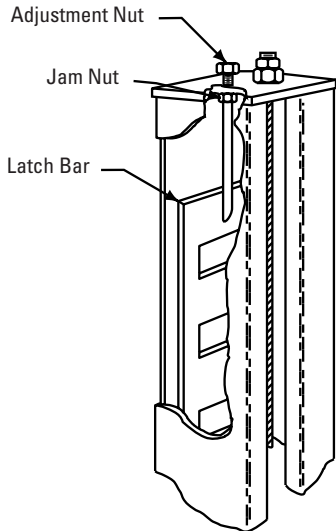
With the openings in the yoke tube side lined up with the left runway ends, align the two (2) holes in the top of the front yoke tube with the slots in the runway end plates and the holes in the front wheel stops. Bolt runway to the yoke using four M12-30 hex flange bolts, Fig. 4.

#### IMPORTANT

Be sure cables are not crossed inside yoke.

## 6. Column and Yoke Assembly:

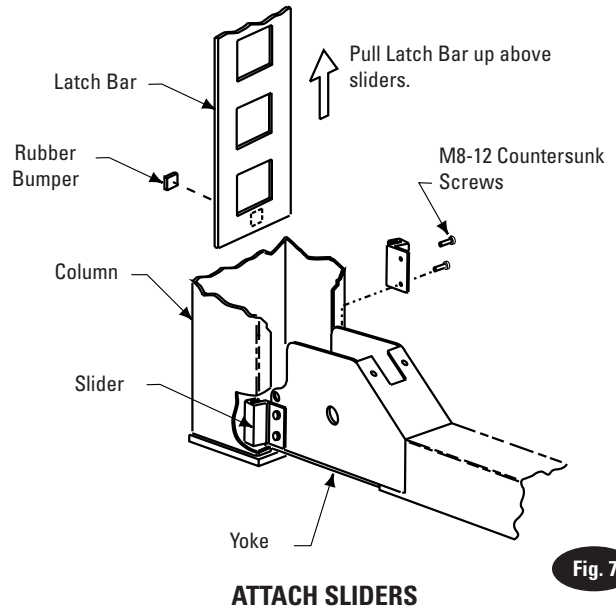
- A. Place the power unit column at the left front corner of the lift. The hydraulic cylinder connection in the left runway should be visible from this corner. Position remaining three columns.



**LATCH BAR IN COLUMN**

**Fig. 5a**

- B. Retain sheave pin with (2) M10-16 bolts and sheave pin retainer. Attach each cable to column top plate with spacer, nut, and jam nut, Fig. 8. Install plastic sheave guard on each yoke end, Fig. 8. Roping diagram shows a view of completed roping, Fig. 9.
- C. Thread the jam nut down the threaded stud as far as possible. Stick rubber bumper to bottom of latch bar, see Fig. 7. Place the latch bar in the back of the column, Fig. 5a.



**Fig. 7**

- D. Start yoke end into the column, allowing slider bolt holes to stay exposed, Fig.7. Then bolt sliders onto each side of the yoke end with M8-12 countersunk screws provided. When both sliders are attached, push column toward yoke end until sliders touch latch bar.
- E. Raise latch bar and column above sliders and move column toward yoke until the sliders contact the back of the column. Lower the latch bar into the sliders. Tighten latch bar jam nut against column top plate. Run latch bar adjustment nut down and tighten. The latch bar should engage the sliders for at least 1" (25mm) when the lift is completely lowered. Repeat this procedure for each yoke end and column.
- F. Install yoke end sheaves and plastic spacers, Fig. 8. A plastic spacer is placed on each side of the sheave, inset Fig. 8.

Note: Failure to install plastic spacer will result in premature failure and void warranty.

### **IMPORTANT**

Be sure cable is located in the sheave groove.

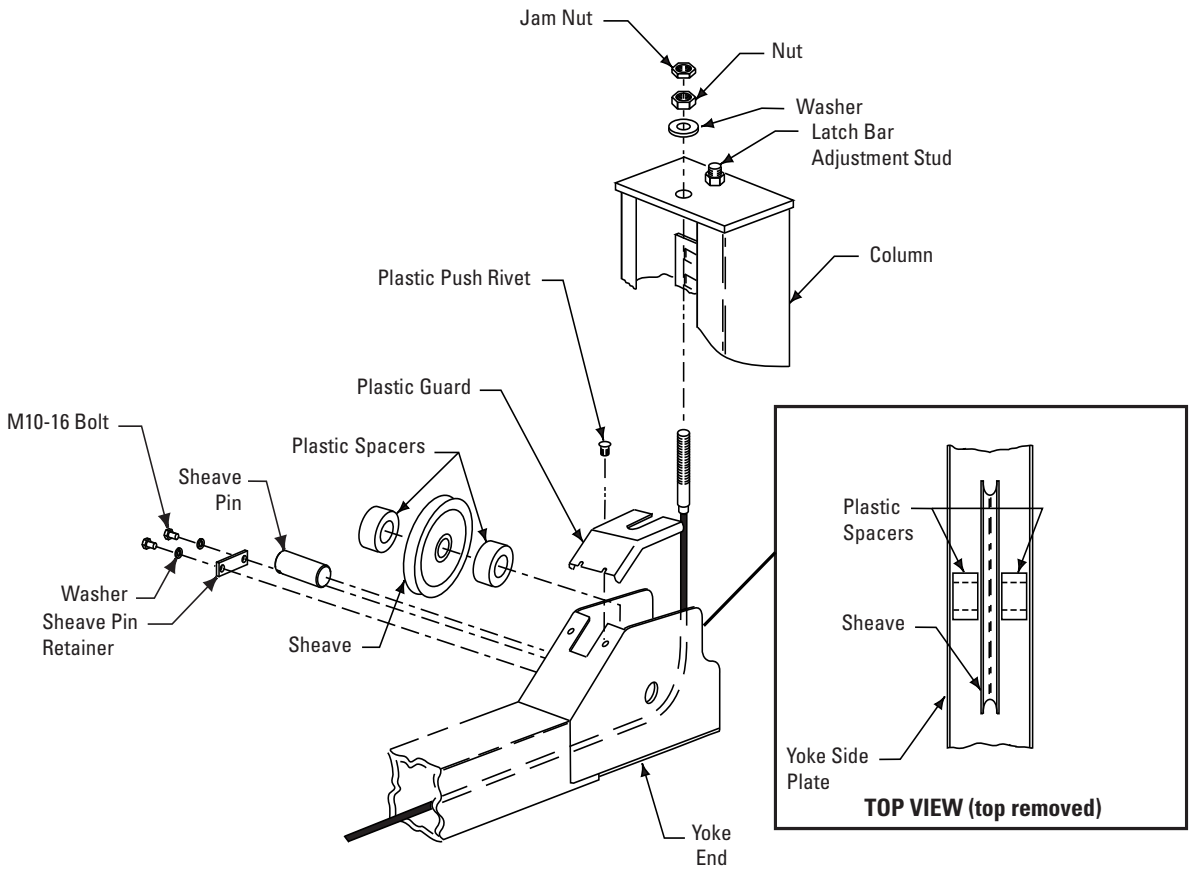


Fig. 8

**SHEAVE INSTALLATION**

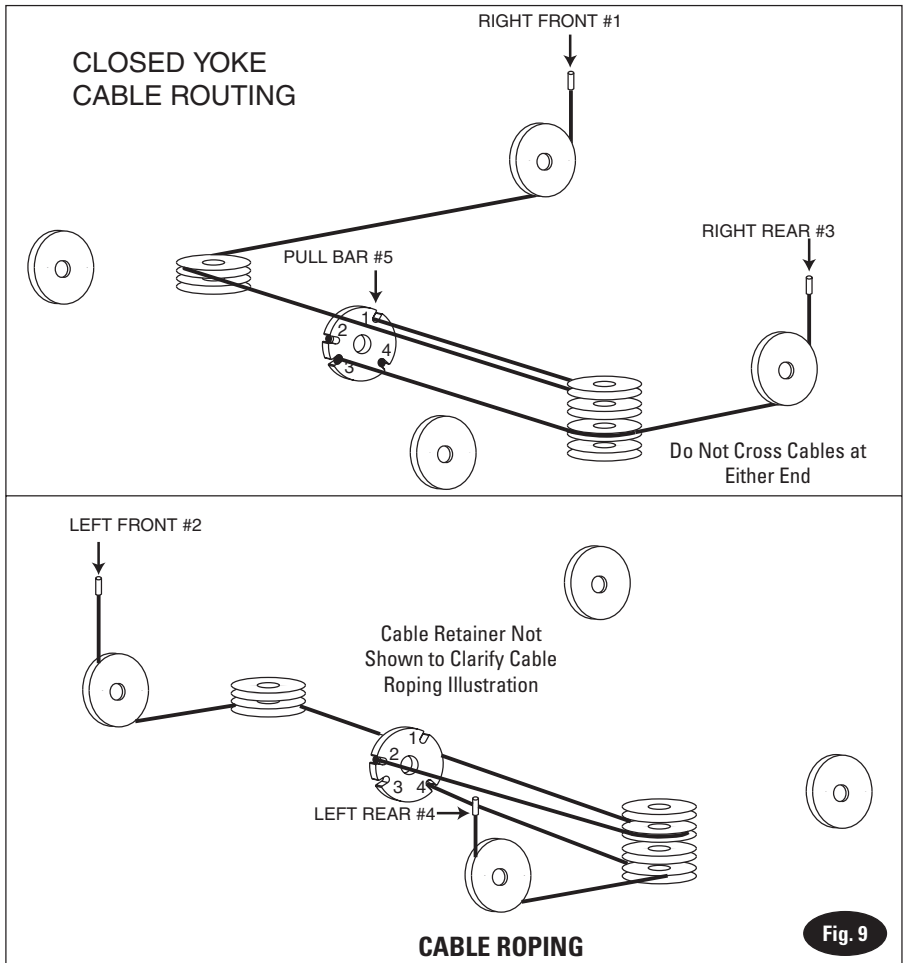
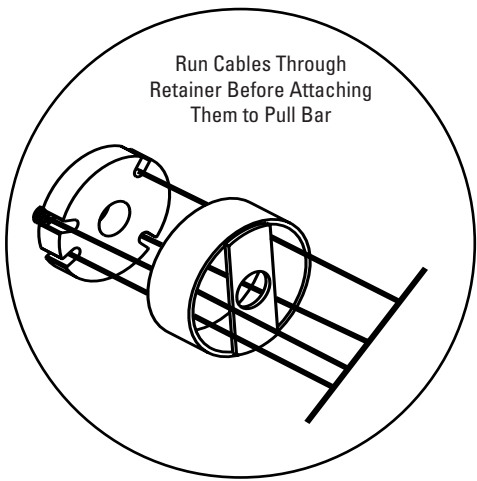


Fig. 9

## 7. Column Anchoring:

- A. Keep columns square to center line of lift. Check lift location in the bay. Check dimensions side-to-side, front-to-rear, and diagonally. Diagonals must be equal to within 1/4" (6mm), Fig. 11.
- B. Move column towards yoke until the sliders contact the back of column, center yoke in column, Fig. 10.

- C. Place shims (estimated in Step 3) under each column. Drill four 5/8" diameter holes through concrete floor using base holes as guide. See Fig. 12a and 12b for hole depth, hole spacing, and edge distance requirements. Repeat for other columns.
- D. Insert base anchors, Fig.'s 12b and 13.
- E. Tighten nuts, Fig. 12b. Check columns for plumb and level. Re-shim if necessary. Torque anchor bolts to 60 ft. lbs. (81 Nm), Fig. 12b.
- F. If anchor bolts do not hold when torqued to required amount, concrete must be replaced. Saw cut and remove 24" x 24" (610 x 610mm) square area under each column base. Repour with reinforced 3000 psi (20684 kPa) minimum concrete to depth of 6" (152mm), keying new concrete under existing floor.

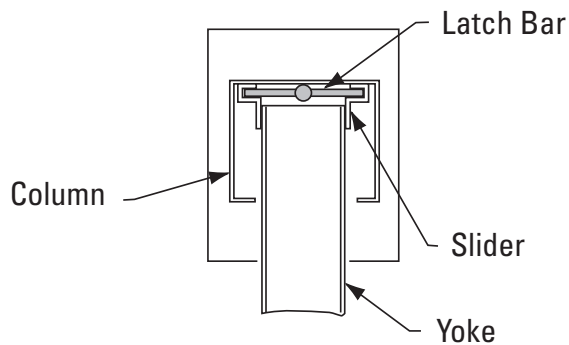


Fig. 10

### COLUMN CROSS SECTION

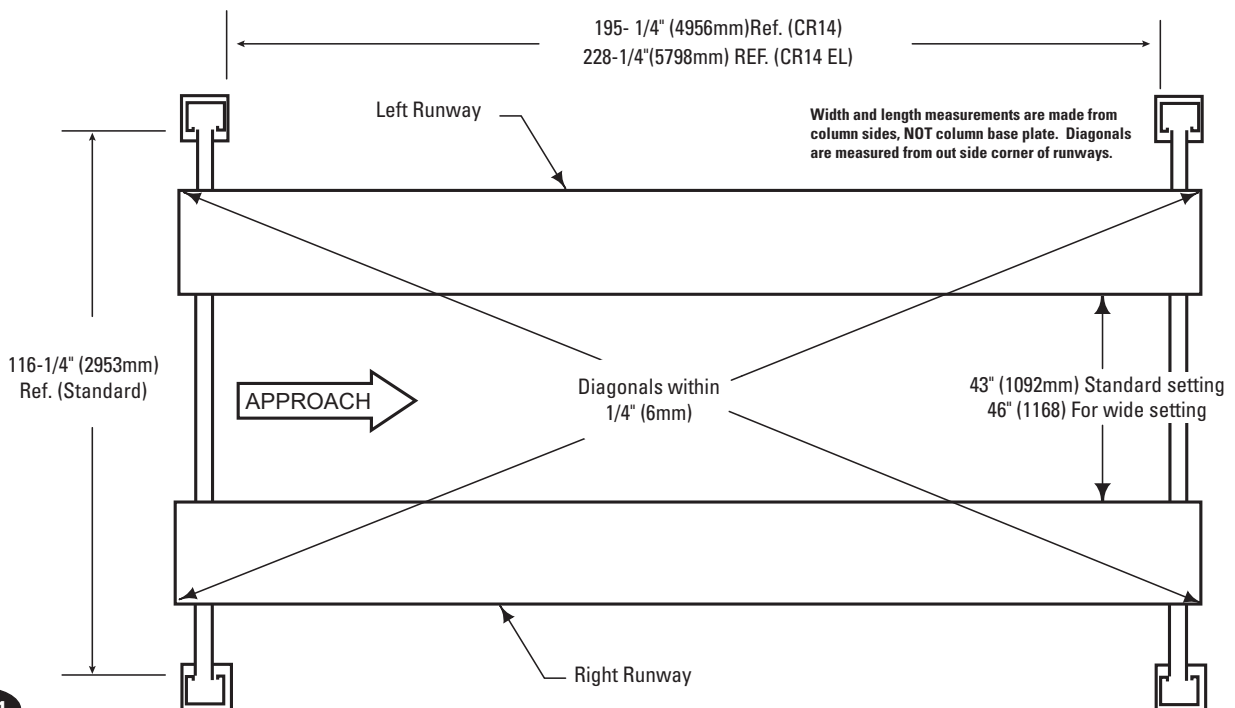
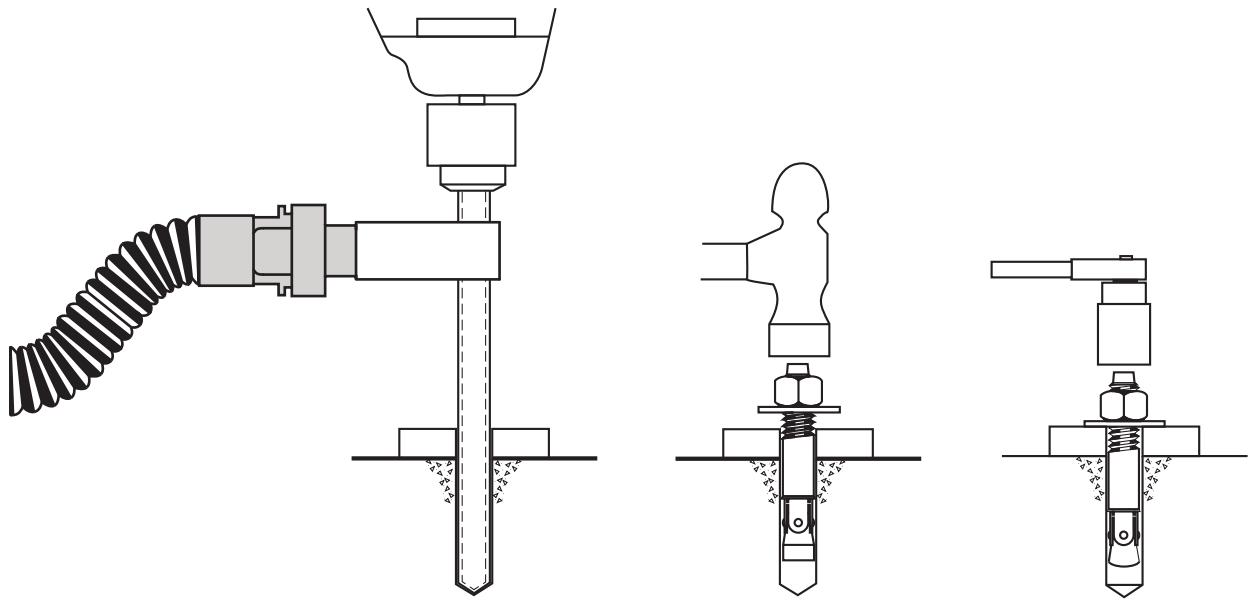


Fig. 11

### CHECK DIAGONALS



Drill holes using 5/8" carbide tipped masonry drill bit per ANSI B212.15-1994 (R2000). Construction dust collected per OSHA 29 CFR 1926.1153.

Run nut down just below impact section of bolt. Drive anchor into hole until nut and washer contact base.

Manually hand tighten nut with torque wrench to 60 ft.-lbs. (81 Nm).

Fig. 12a

Note: KB1 and KB3 Anchors are NOT interchangeable.

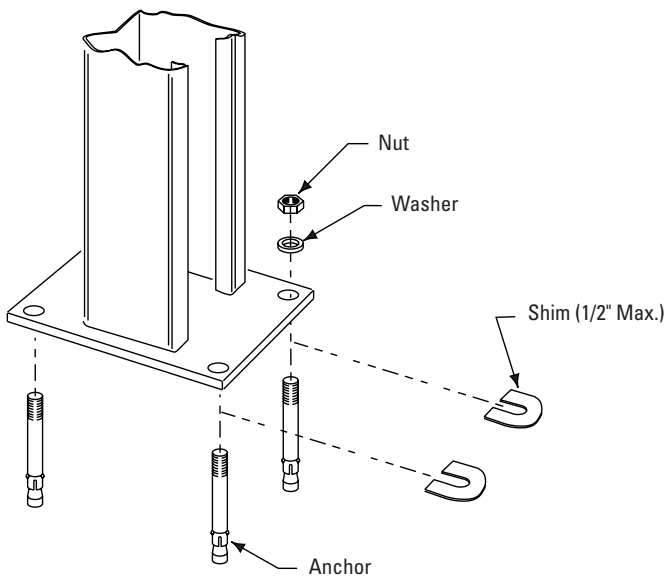
### 14K 4-Post Lift Anchor Installation Reference Guide

Anchor:	Min Concrete Thickness	Min Edge Distance	Min Anchor Embedment	Installation Anchor Torque (ft.-lbs)	Min Concrete PSI Strength - For All Standards	Concrete pad Size If Concrete Does Not Meet Requirements	Maintenance Torque Values** (ft.-lbs)	SEISMIC
Hilti Kwik Bolt I (5/8" x 4-3/4")	3-5/8" (92mm)	7" (178mm)	2-3/4" (70mm)	60 (81Nm)	3000 (20684 kPa)	2'x2'x6" (610 x 610 x 152mm)	50 (68Nm)	Varies by location consult with your structural engineer and manufacturer's representative.
Hilti Kwik Bolt III (5/8" x 4-3/4")	3-5/8" (92mm)	4-1/4" (108mm)	2-3/4" (70mm)	60 (81Nm)	3000 (20684 kPa)	2'x2'x6" (610 x 610 x 152mm)	50 (68Nm)	
Hilti HY200 Epoxy (with HAS threaded rod) 5/8" Dia.	5" (127mm)	2 1/4" (57mm)	3-1/8" (80mm)	60 (81Nm) / less than 2" (51mm) edge distance use Torque Value of 18 ft.-lbs (24Nm)	3000 (20684 kPa)	2'x2'x6" (610 x 610 x 152mm)	N/A	

\*The supplied concrete fasteners meet the criteria of the American National Standard

"Automotive Lifts - Safety Requirements for Construction, Testing, and Validation" ANSI/ALI ALCTV-2011, and the lift owner is responsible for all charges related to any additional anchoring requirements as specified by local codes. Contact customer service for further information at: 800.640.5438

Fig. 12b



**Fig. 13** INSERT ANCHORS

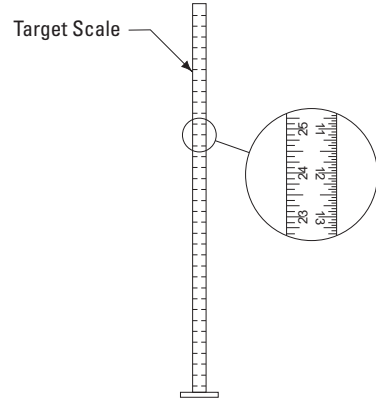
**8. Runway Leveling:**

- A. Use an engineer's automatic level (transit). Locate the Level at a convenient location in the shop that allows an unobstructed view of all four corners of the lift's runways. Follow the Level manufacturer's instructions for proper setup. Be sure it is adjusted level in all directions. Readjust level if it or tripod is bumped or disturbed.
- B. Make sure yoke tubes rest on column base plate.
- C. First place the Level target at the highest corner of the lift. Place it on the runway center line within 6" (152mm) of yoke tube, whichever one is located over highest point. This will be referred to as target "A" position. Beginning with target "A" position, Fig. 14, sight the Level to the target and mark the number or the graduation on the inch scale of the target that aligns to the crosshairs of the Level, Fig. 15.

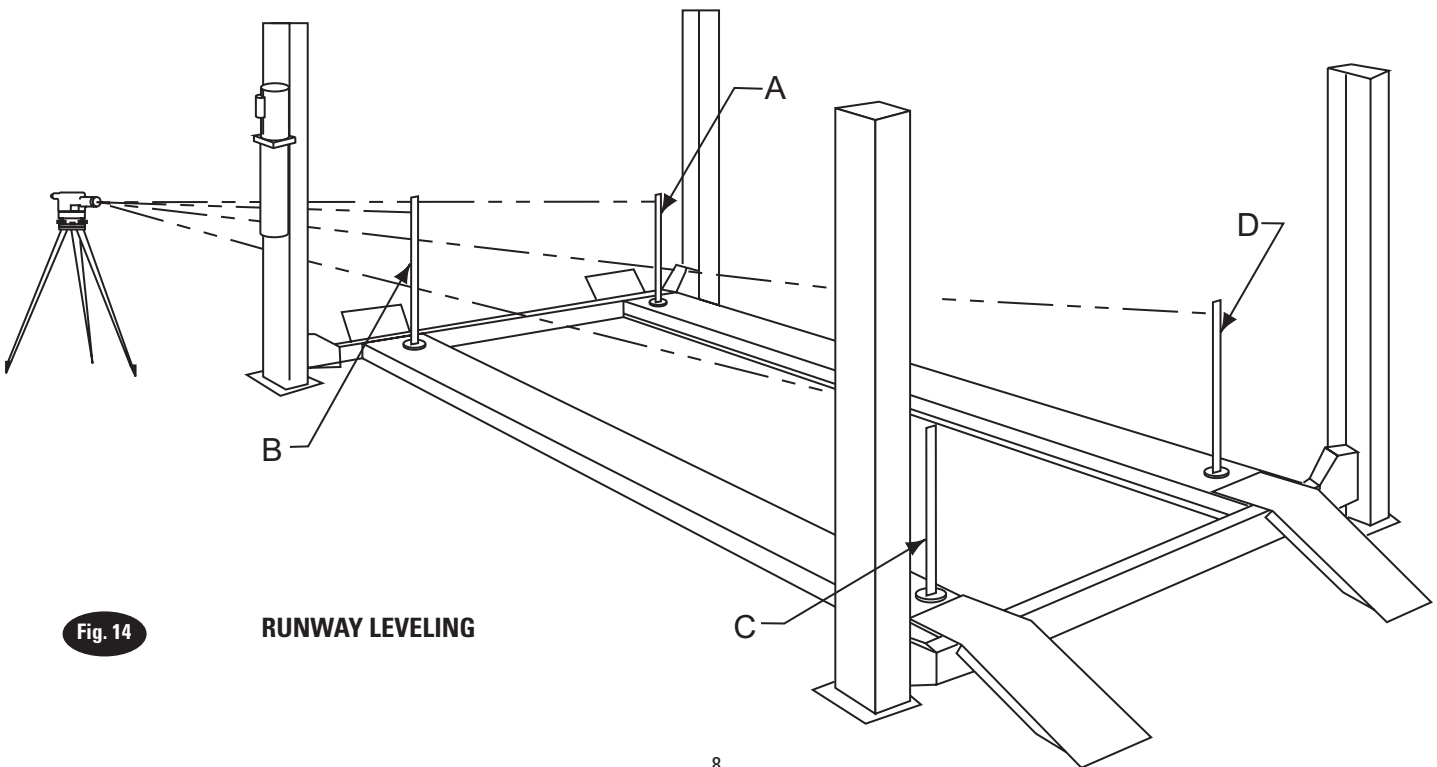
**RUNWAYS SHOULD BE LEVEL MAXIMUM TOLERANCE SIDE TO SIDE AND FRONT TO REAR 1/8" (3MM)**

**Note:** Use a pencil, marking pen or attach a paper clip on to the target scale at the crosshair reference.

- D. Next, move the target and place it on the runway at point "B", Fig. 14. Rotate the Level and focus on the target scale. Adjust the column at "B" using shims under base plate, Fig. 13, until the cross-hairs of Level align to reference mark on the target scale. Repeat for points C and D.



**TARGET SCALE** **Fig. 15**



**Fig. 14** RUNWAY LEVELING

### 9. Cable Adjustment:

Adjust cable with lift fully lowered. Loosen jam nut and tighten nut on cable stud on top of column until yoke end raises 1/4" (6mm). Back off nut one turn. Retighten jam nut. Repeat for all four cables. Refer to Fig. 8.

**IMPORTANT** Cables must fit in slack cable arm rollers, Fig. 16.

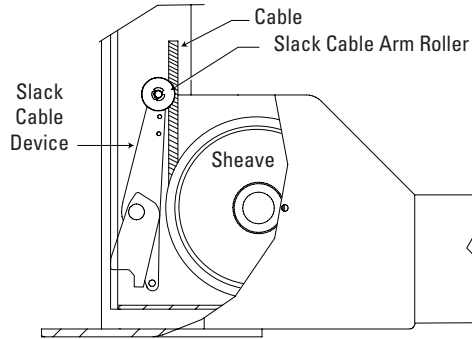


Fig. 16

CABLE IN SLACK CABLE ARM

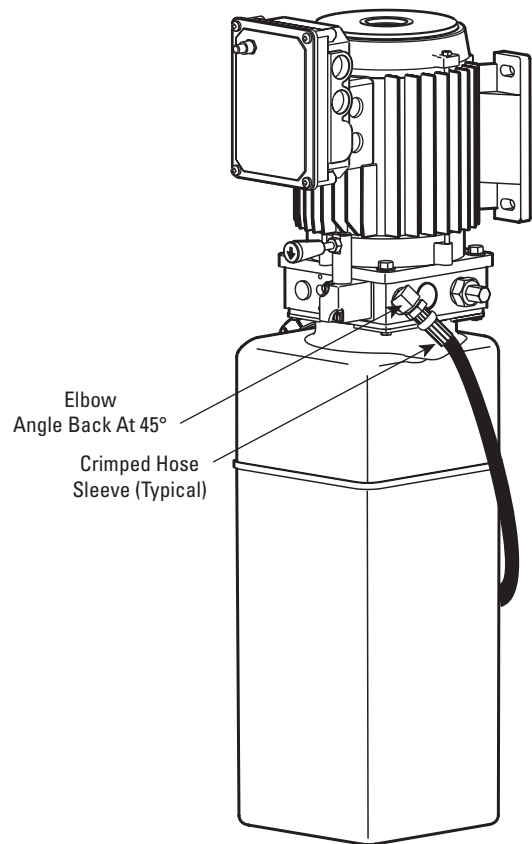


Fig. 17

### 10. Power Unit:

- Put (4) M8-35 hex bolts through holes in column bracket using push nuts to hold in place.
- Mount power unit with motor up, Fig. 18 to column bracket and install washers and nuts. Run hydraulic hose from runway through slot in side of runway to power unit output port, Fig. 19. DO NOT use Teflon tape on hydraulic hose connections.
- Install and hand tighten elbow to pump until O-ring is seated and elbow should be oriented downward at approximately 45°, Fig. 17. Tighten locknut to 35-40 ft-lbs. (47-54 Nm) Install enclosed Capacity label on power unit, Fig. 18.
- Run hydraulic hose from runway through slot in side of runway to elbow, Fig. 22. DO NOT use Teflon tape on hydraulic hose connections. Clean elbow and hose. Inspect all threads for damage and hose ends to be sure they are crimped. Attach hose to elbow using Flared Fittings Tightening Procedure.

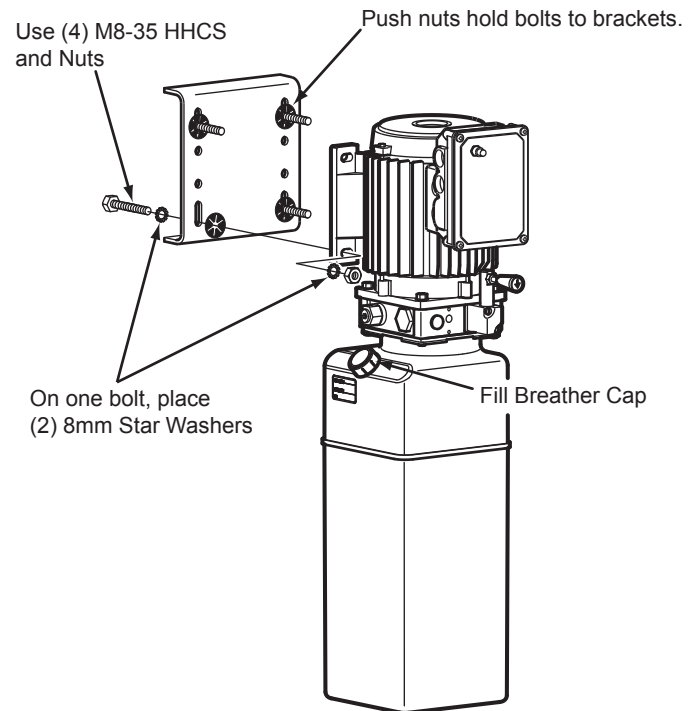


Fig. 18

- 11. Electrical:** Have a certified electrician run appropriate power supply to motor, Fig. 20, Fig. 21, & Fig. 21b. Size wire for 20 amp circuit. See Motor Operating Data Table.

**CAUTION** Never operate the motor on line voltage less than 208V. Motor damage may occur.

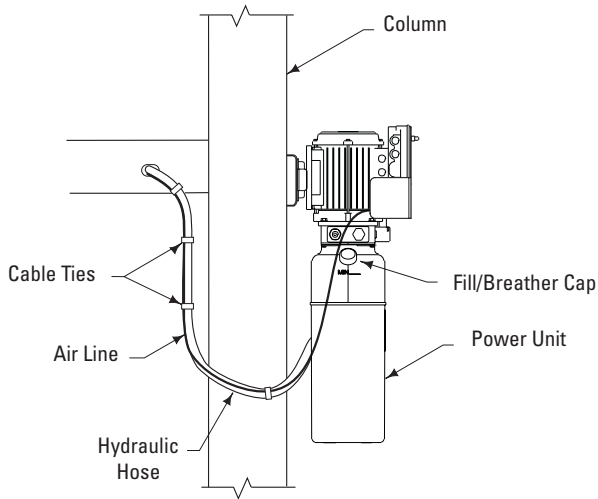


Fig. 19

**IMPORTANT** Use separate circuit for each power unit. Protect each circuit with time delay fuse or circuit breaker. For single phase 208-230V, use 20 amp fuse. Three phase 208-240V, use 15 amp fuse. For three phase 400V and above, use 10 amp fuse. For 3Ø wiring see Fig. 21. All wiring must comply with NEC and all local electrical codes.

Note: 60Hz. single phase motor CAN NOT be run on 50Hz. line without a physical change in the motor.

**12. Hydraulic Fluid Filling:** System capacity is fourteen (14) quarts. Use Dexron III ATF. Remove fill/breather, Fig. 19. Pour in fourteen (14) quarts of fluid. Replace fill/breather. Start motor and raise lift to full rise. Lower onto latches.

**Note:** If fill/breather, Fig. 19, is lost or broken, order replacement.

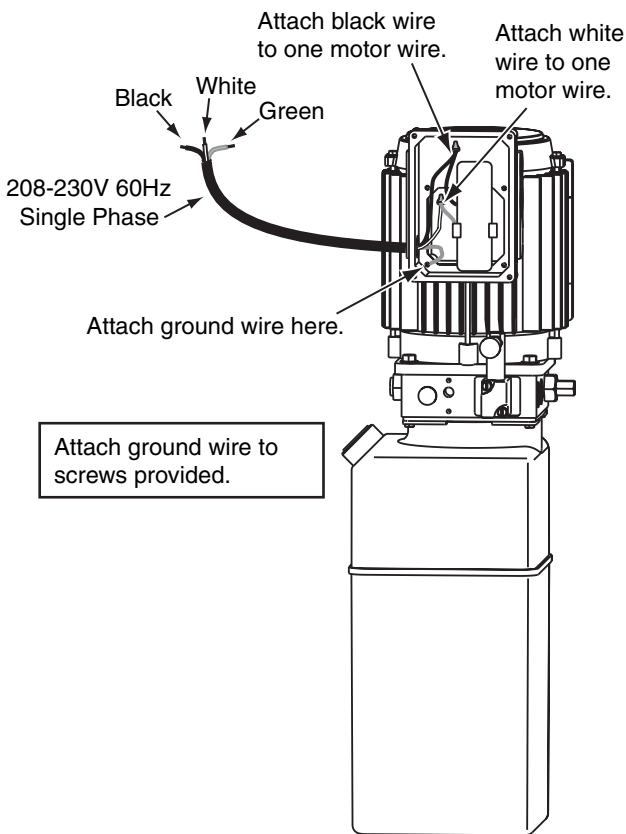
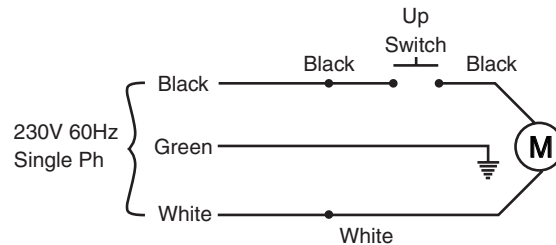


Fig. 20

### Single Phase Power Unit

MOTOR OPERATING DATA TABLE - SINGLE PHASE	
LINE VOLTAGE	RUNNING MOTOR VOLTAGE RANGE
208-230V 50Hz.	197-253V
208-230V 60Hz.	197-253V

**Note:** 60Hz. Single phase motor CAN NOT be run on 50Hz. line without a physical change in the motor.

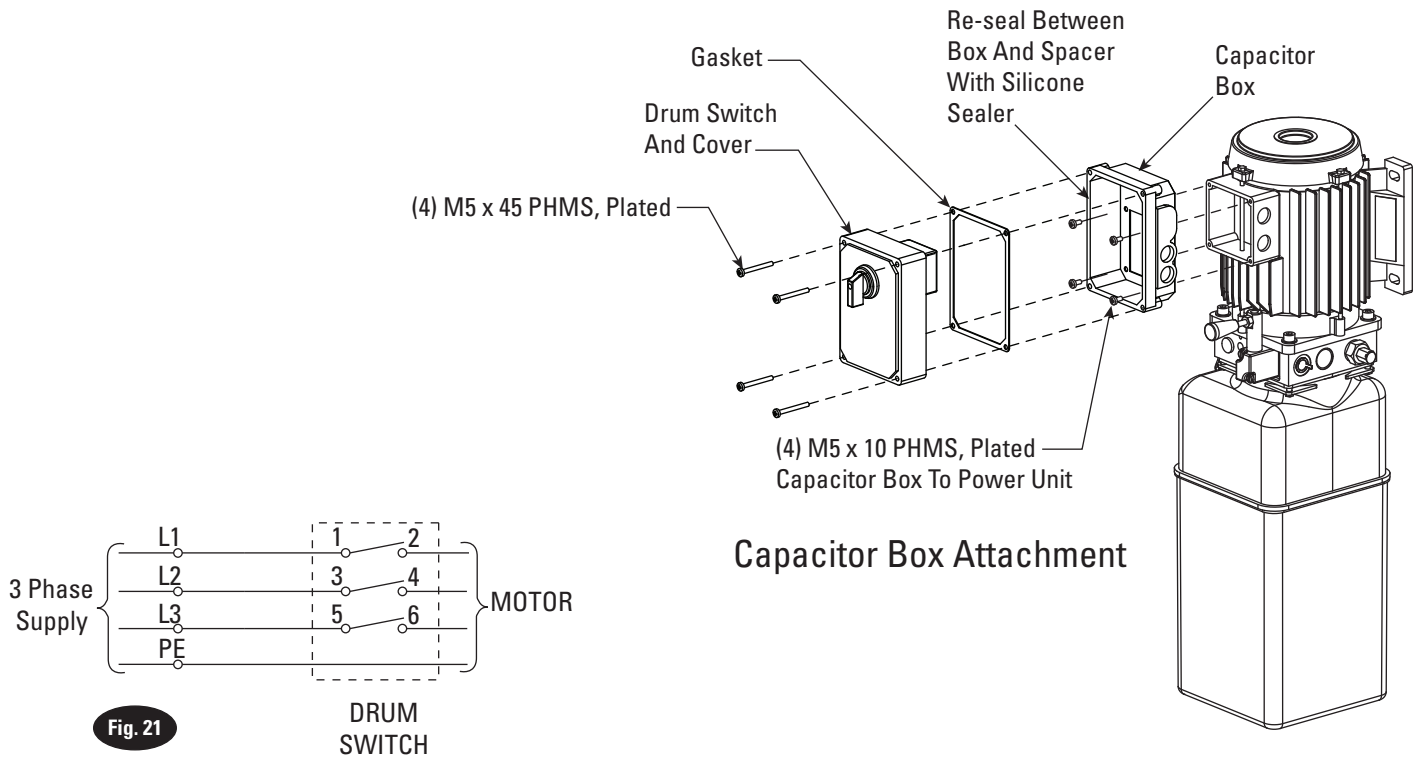


MOTOR OPERATING DATA TABLE - THREE PHASE	
LINE VOLTAGE	RUNNING MOTOR VOLTAGE RANGE
208-240V 50/60Hz.	197-253V
400V 50Hz.	360-440V
440-480V 50/60Hz.	396V-528V
575V 60Hz.	518V-632V

**NOTES:**

1. Unit not suitable for use in unusual conditions. Contact your authorized parts/service center for moisture and dust environment duty unit.
2. Control Box must be field mounted to power unit.
3. Motor rotation is counter clockwise from top of motor.

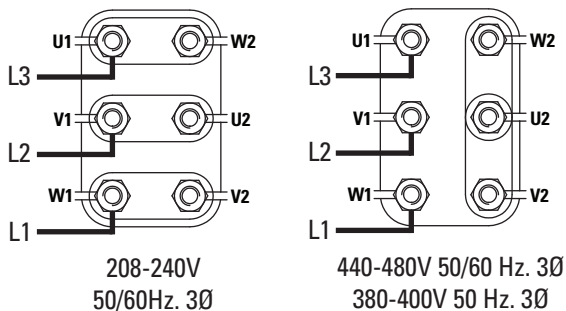
**Note:** Newer model three phase lifts use the push button control box with contactor. Its instructions follow the Drum Switch instructions.



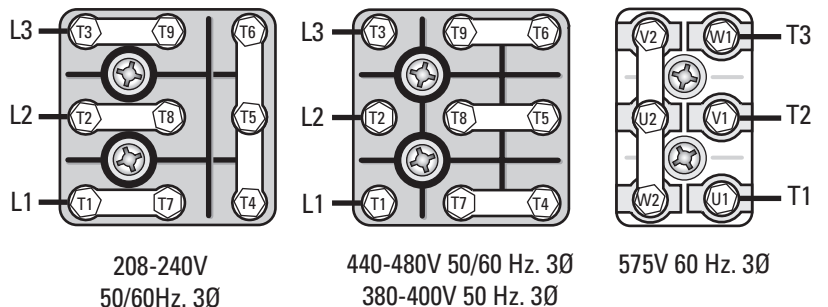
### Three Phase Power Unit

MOTOR OPERATING DATA TABLE - THREE PHASE	
LINE VOLTAGE	RUNNING MOTOR VOLTAGE RANGE
208-240V 50/60Hz.	197-253V
400V 50Hz.	360-440V
440-480V 50/60Hz.	396V-528V
575V 60Hz.	518V-632V

#### Current Pin Layouts



#### Older Pin Layouts

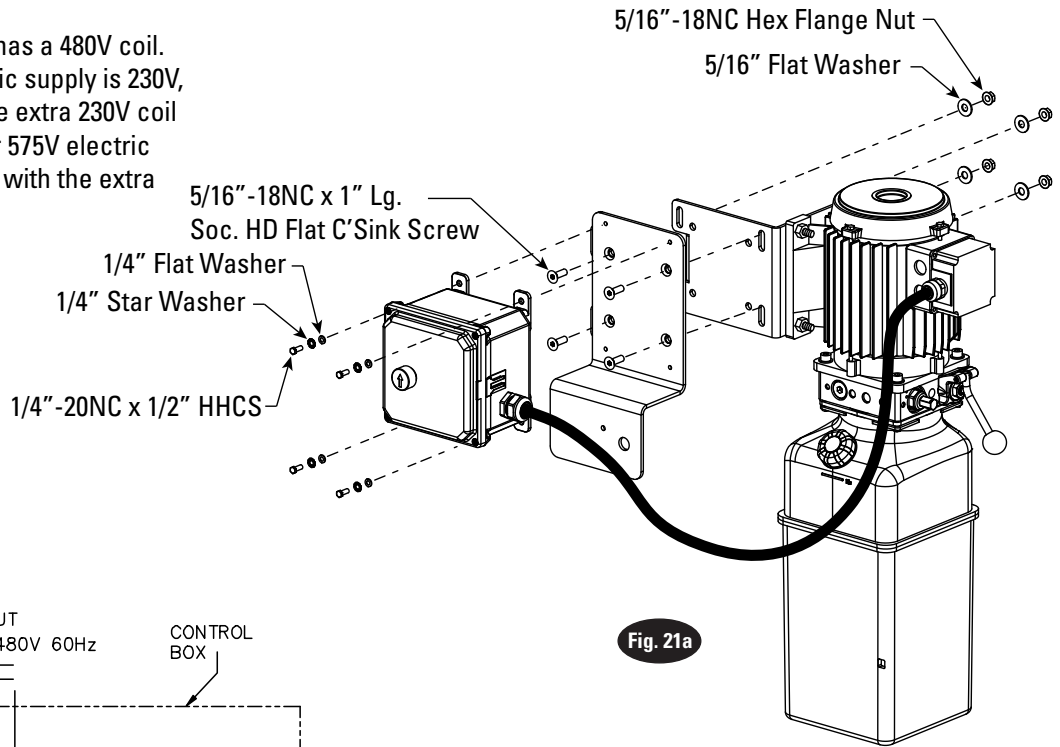


**13. 3Ø Control Box Installation:**

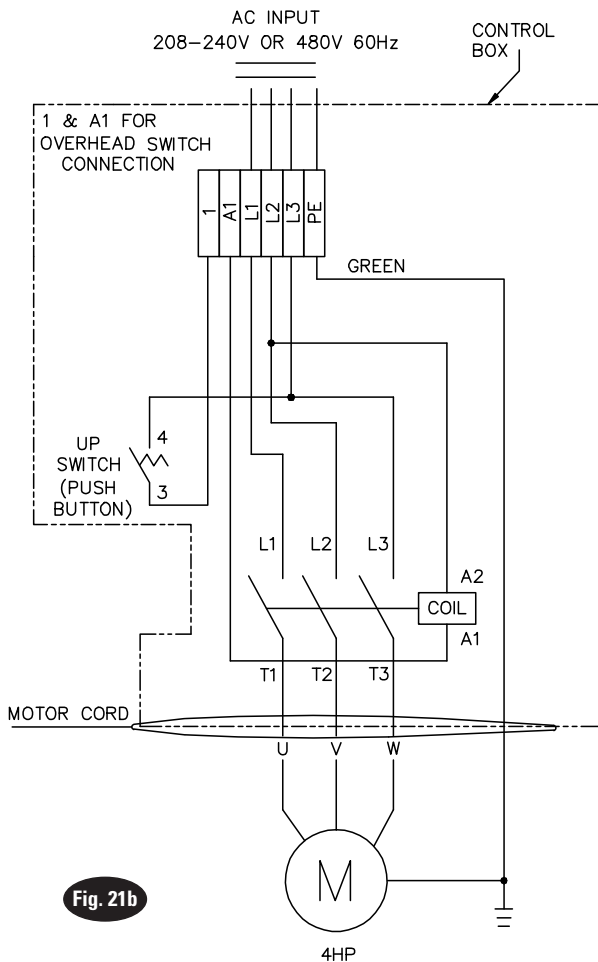
- A. Attach Mounting Bracket to the Power Unit Bracket using (4) 5/16"-18NC x 1" Lg. Soc HD Flat C'Sink Screws, (4) 5/16" Flat Washers, and (4) 5/16"-18NC Hex Flange Nuts, Fig. 21a.
- B. Attach Control Box to Bracket using (4) 1/4"-20NC x 1/2" HHCS, (4) 1/4" Flat Washers, and (4) 1/4" Star Washers. Fig. 21a.
- C. Route cord through strain relief on motor and connect per table on the bottom of page 11.

**Note:**

The contactor in the control box has a 480V coil. For installations where the electric supply is 230V, the coil must be replaced with the extra 230V coil shipped with the control box. For 575V electric supply, the coil must be replaced with the extra 575V coil shipped with the lift.



**Fig. 21a**



**Fig. 21b**

#### 14. Air Line Connections:

**Note:** Locking latches require 100 psi. (689 kPa.) min. to 120 psi. (827 kPa.) max. air pressure.

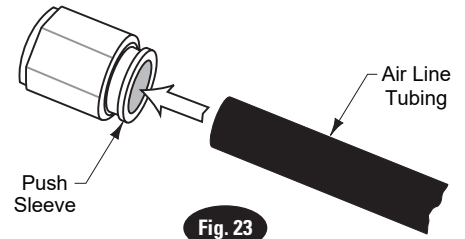
A filter/regulator/lubricator must be installed on air supply at lift. Failure to do so will void the warranty.

- A. Lift should be at full height and lowered on latches.
- B. Run 3/8" air line from existing facility main air supply to the FRL. Run 3/8" air line from FRL to reducing tee, Fig. 22.
- C. Connect air valve to Reducing Tee, Fig. 22.  
Cut provided 1/4" air line tubing with sharp blade to length as required. Tubing must be cut square with no burrs.

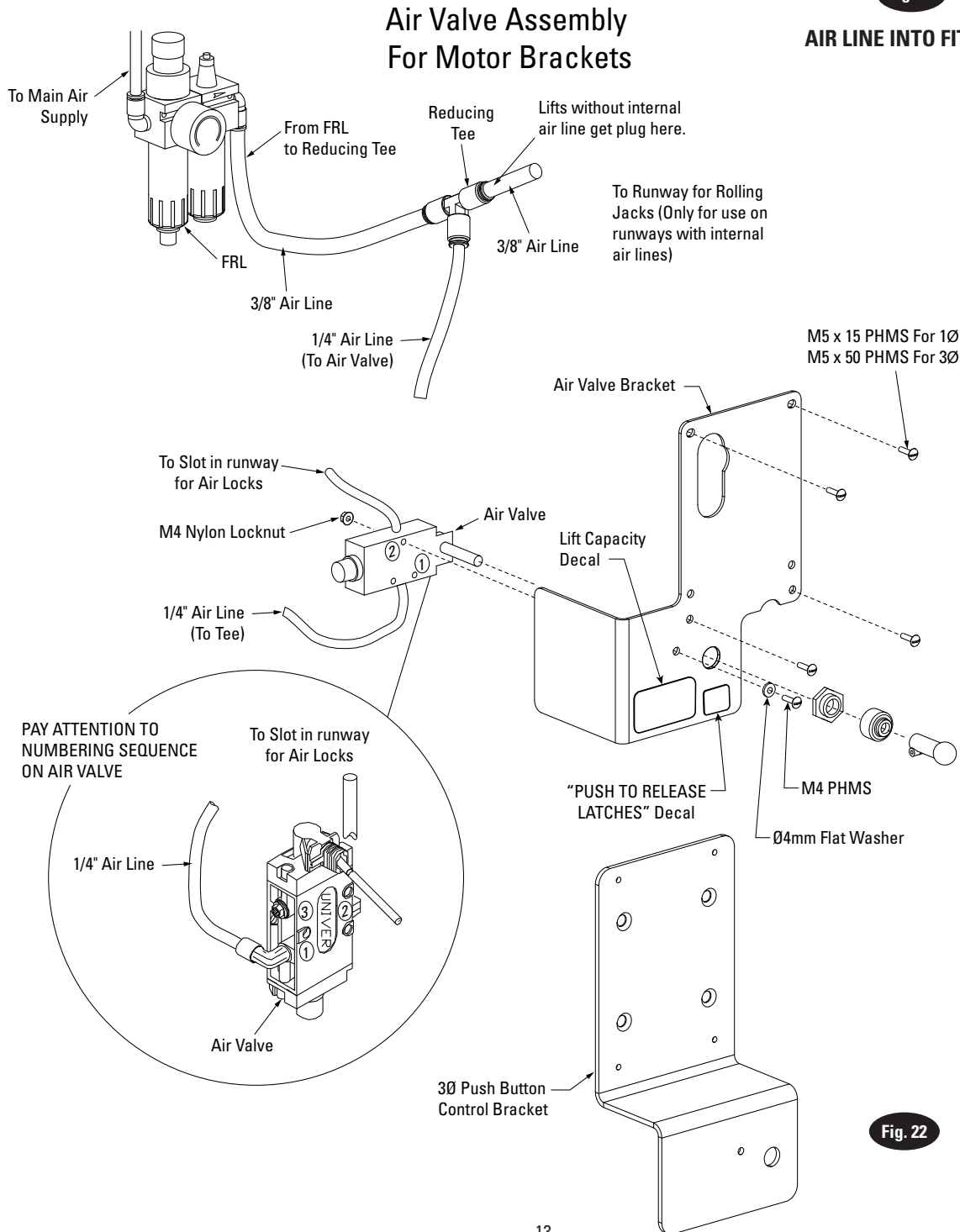
**Note:** To assemble air line tubing into fitting, use firm, manual

pressure to push tubing into fitting until it bottoms, Fig. 23. If removal of the air line tubing from the fitting is ever required, hold Push Sleeve in (against fitting) and, at the same time, pull out on tubing.

- D. Attach air valve to air bracket (or 3Ø Push Button Control Bracket when used), see Fig. 22.



**AIR LINE INTO FITTING**



**Fig. 22**

**E. Air Valve Bracket:**

Remove motor warnings decal from motor cover. Remove motor cover screws. Place air valve bracket on top of motor cover so that the raise switch protrudes through the hole in the air valve bracket. Mount air valve bracket and motor cover with the existing single phase (4) M5 x 15 PHMS motor cover screws or supplied M5 x 50 PHMS for three phase, Fig. 22.

**F. Attach enclosed decals NP280 ("PUSH TO RELEASE LATCHES") and NP864 (LIFT CAPACITY) below button on air valve bracket, Fig. 17. Run 1/4" air line from air valve to the slot in the fixed runway. Cut airline and attach a Tee, Fig. 25, 22.**

**G. Run 1/4" air line from the Tee in the front yoke through air output on the air valve, Fig. 22, and Fig. 25.**

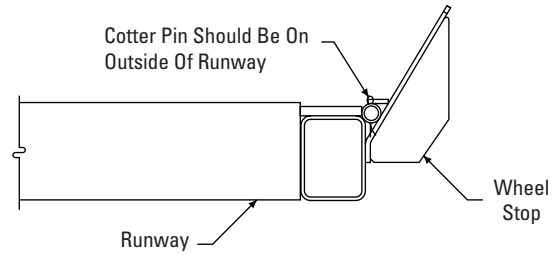
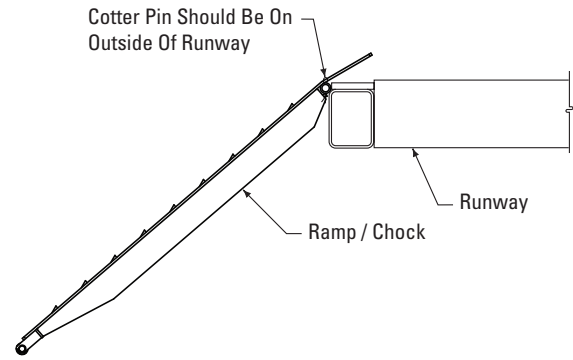
**H. If lift has internal air, remove plug in reducing tee and connect the 3/8" line coiled inside of runway, Fig. 22.**

**I. Check for air leaks by depressing air valve. Repair as required.**

**J. Use provided cable ties to tie air line to hydraulic hose between power unit and lift.**

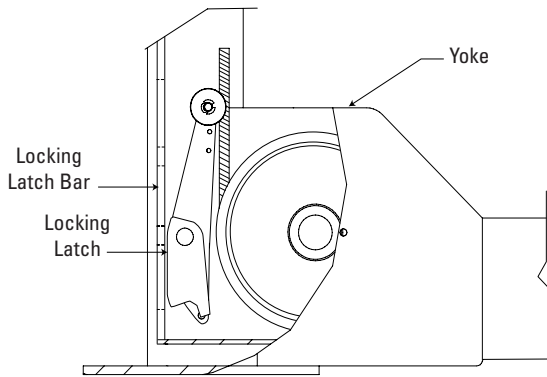
**K. Actuate air valve and check latch operation on all four corners. The locking latches should pull in beyond yoke ends to clear the latch bars located in all four columns, Fig. 24.**

**L. Use cable ties provided to tie 3/8" air supply to electrical supply conduit at approximately 2'-0" (610mm) intervals.**



**Fig. 26**

**WHEEL STOP / RAMP CHOCK ATTACHMENT**



**Fig. 24**

**LATCHES SHOULD CLEAR LATCH BARS**

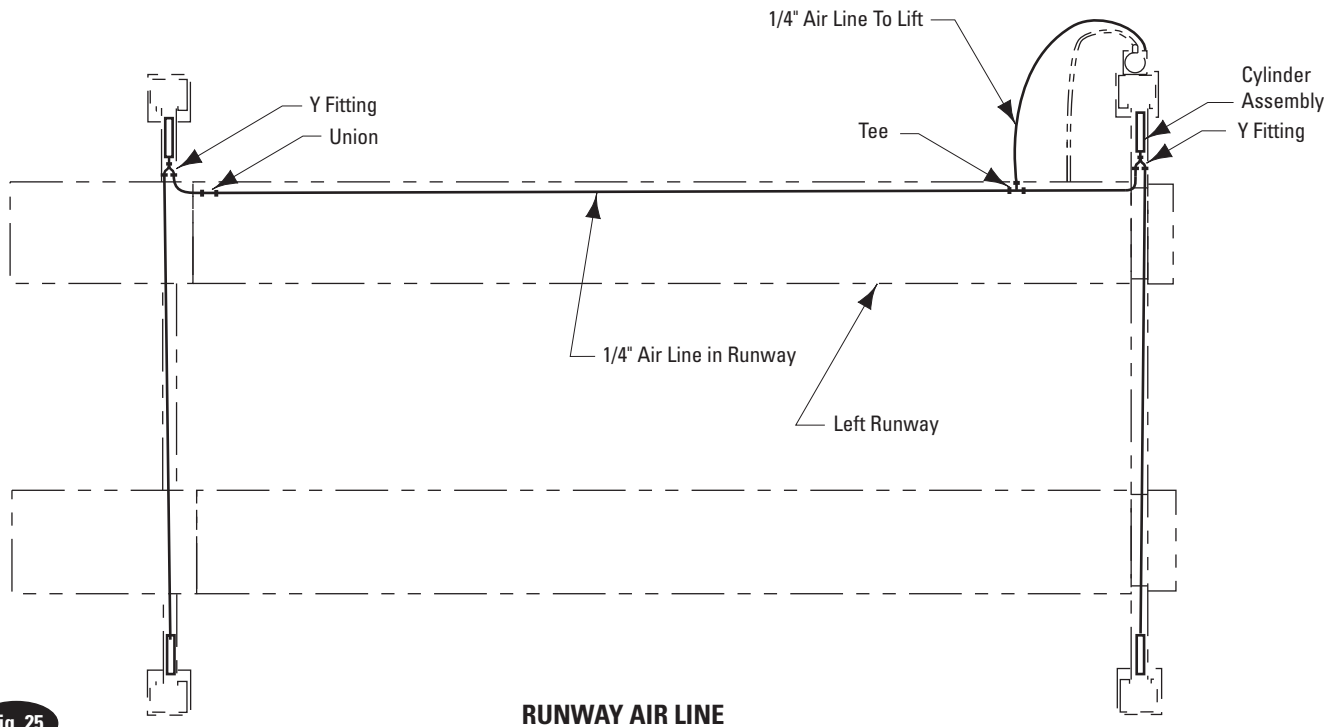


Fig. 25

**RUNWAY AIR LINE**

- 15. Bleeding:** Lift must be fully lowered before changing or adding fluid. Raise and lower lift six times. The cylinder is self-bleeding. After bleeding system, fluid level in power unit reservoir may be down. Add more ATF, if necessary, following instructions in Step 12.

To pressure test, run lift to full rise and run motor for approximately 5 seconds. Stop and check all fittings and hose connections. Tighten or reseal if required. Lower lift. If fill/breather, Fig. 19, is lost or broken, order replacement.

**Note:** Some test fluid may be spilled from the cylinder breather vent during bleeding of the system.

- 16.** Assemble ramp/chocks to rear of runways using hinge pins and cotter pins, Fig. 26.

**17. Final Adjustments:**

- A. Load vehicle such as an RV onto lift.
- B. Raise lift to full height. You will hear the locking latch click through all 18 latch slots.
- C. Lower lift onto topmost latch position.
- D. Check latch clearance.
  1. Starting with the right front column: use a straight edge to mark the yoke height on the column, Fig. 27.
  2. Raise lift to full height again. Mark second position. If gap between two marks is less than 2" (51mm), adjust locking latch bar to reach clearance of 2" (51mm).
  3. Adjust locking latch bar adjusting nut so that the bottom of the topmost latch bar slot is at least 2" (51mm) below locking latch, Fig. 28. After adjustment, tighten jam nut underneath column top plate, Fig. 28.

4. If entire 2" (51mm) clearance cannot be attained by adjusting the locking latch bar, adjust the cable stud. Loosen cable jam nut, Fig. 27, and turn adjusting nut to raise the locking latch 2" (51mm) above bottom of latch bar slot. Tighten cable jam nut. Lower lift and remove vehicle.
- E. Raise the lift to full height. Listen and watch as the locking latches click in place. Synchronize the other three columns with the right front column by adjusting their cables so all four latches click at same time. Tighten jam nuts.

**CAUTION** When making changes to adjustment nuts on cable end or latch bar stud always leave at least two threads showing between nut and end.

**Note:** Latches may not click in at the same time when vehicle is being raised. They should be close. Be sure all four corners have passed the locking latch bar slot before lowering lift on locking latches.

**IMPORTANT** Cotter pins are usually good for one time use only. Replace any cotter pin, if removed, with a new cotter pin.

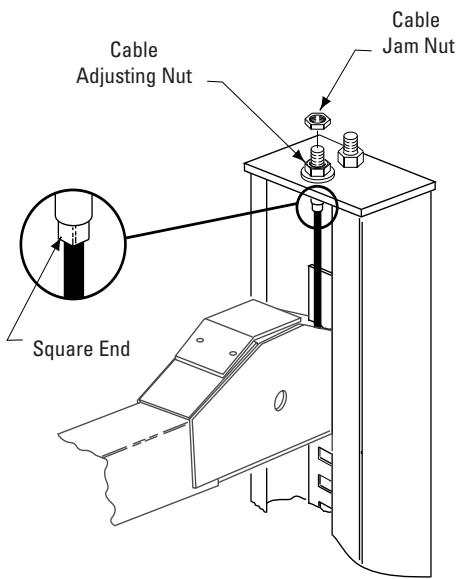


Fig. 27

**1. Runway Leveling Adjustments:**

- A. Engineer's automatic level (transit):
  - 1. Locate the Level, at a convenient location in the shop that allows an unobstructed view of all four corners of the Lift's runways.
  - 2. Follow the Level manufacturer's instructions for proper setup of the Level. Be sure it is adjusted level in all directions.
  - 3. Readjust Level if tripod or Level is bumped or disturbed.
- B. Raise lift approximately 28" - 32" (711-813mm). Then lower lift until all locking latches are engaged in each column and the runways are in full down position on locks.
- C. Place the Level target on the right/front wheel turning radius gauge.
- D. Beginning with "A" position, Fig. 3, sight the Level to the target and mark the number or the graduation on the inch scale of the target that aligns to the cross hairs of the Level, Fig. 29.

**Note:** Use a pencil, marking pen or attach a paper clip onto the target scale at the crosshair reference.

- E. Next, move the target and place it on the turning radius gauge at point "B", Fig. 30.
- F. Rotate the Level and focus on the target scale.
- G. Adjust the adjustment nut on the locking latch plate adjustment stud at the top of the column at "B", Fig. 30, by loosening the jam nut and turning adjustment nut until the cross-hairs of Level align to reference mark on the target scale.

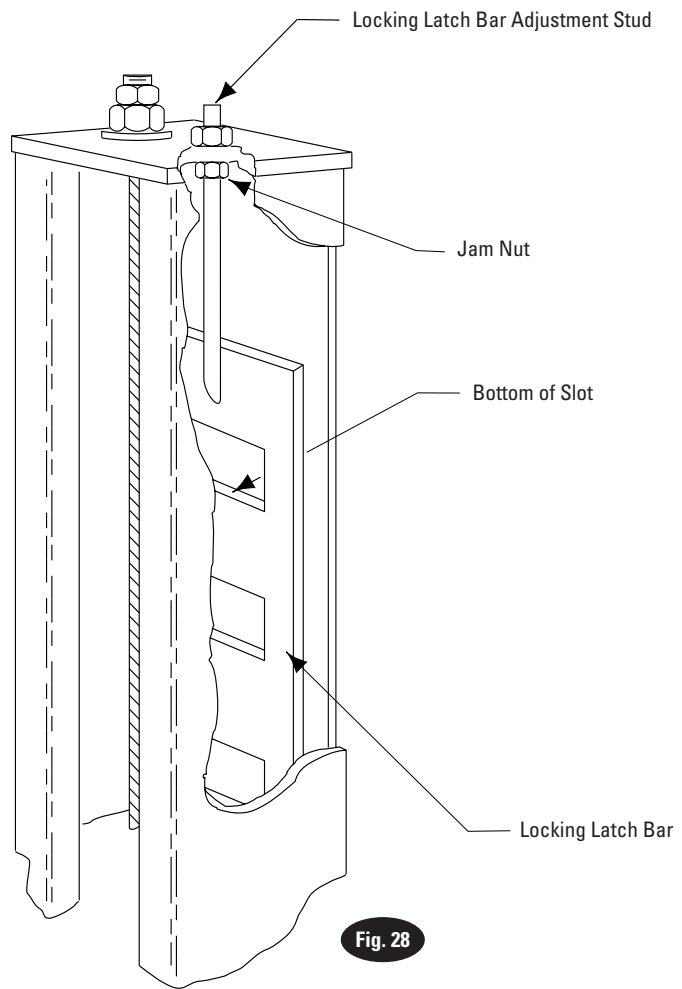


Fig. 28

**ADJUST LOCKING LATCH BAR ADJUSTMENT NUT**

- H. Repeat steps E., F. and G., locating the target assembly at points "C" and "D" and adjusting locking latch plate adjustment stud at each corresponding column until the reference mark on the target scale is on the crosshairs of the Level.

**RACK RUNWAYS MUST BE LEVEL SIDE TO SIDE, MAXIMUM TOLERANCE FRONT TO REAR 1/16" (1.6mm).**

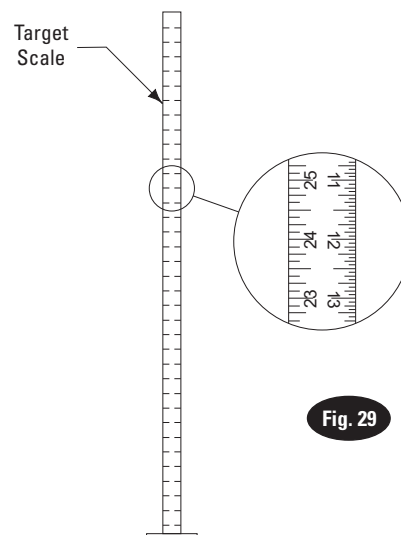


Fig. 29

- I. Always recheck the level of the runways to be sure all four locking latch plates are adjusted correctly. Start at point "A" and recheck level at points "B", "C" and "D", Fig. 31. Readjust, if needed.

**The runways are now level at all four points.**

- J. To complete the leveling procedures, lock each locking latch plate jam nut tightly against bottom of column top plate, Fig. 31.

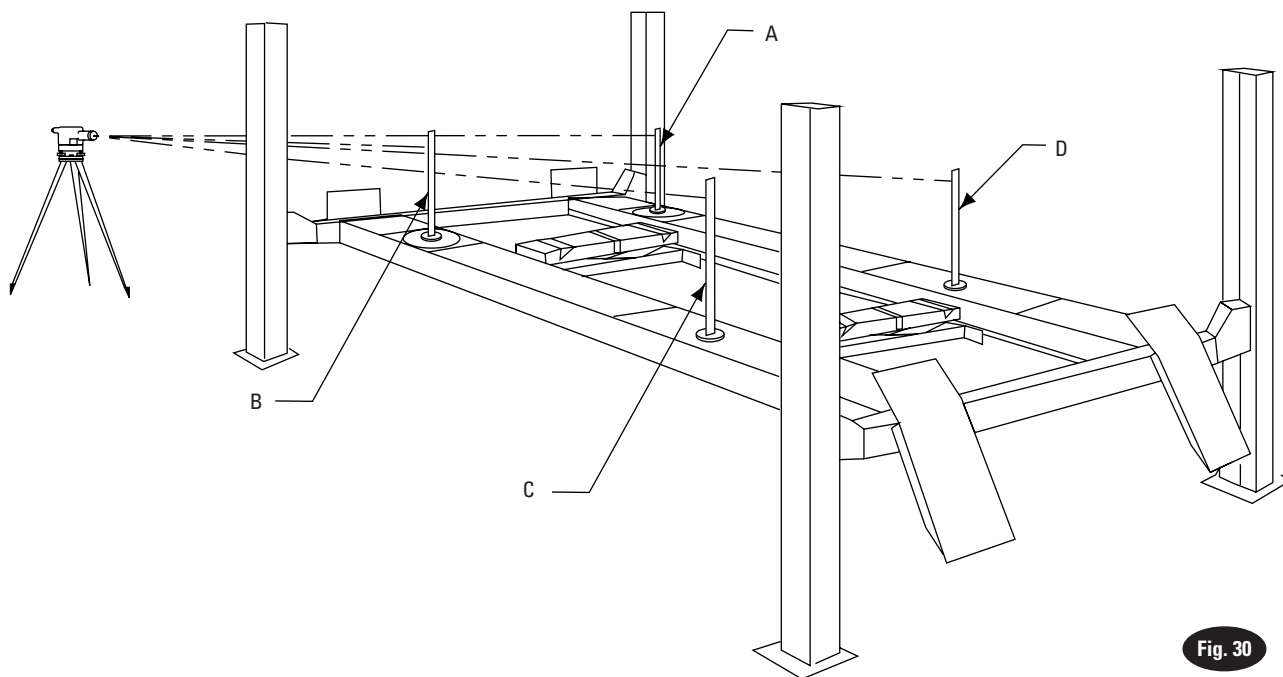


Fig. 30

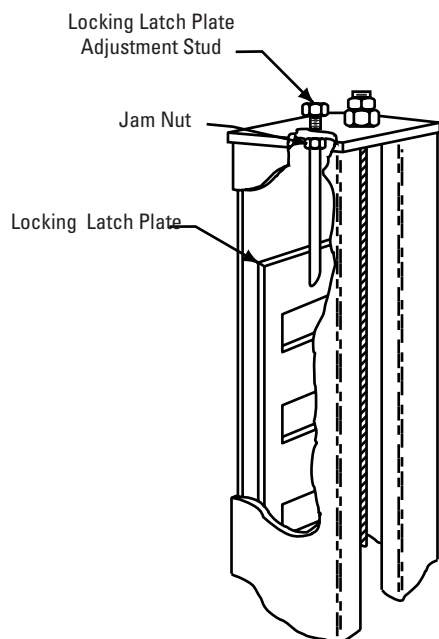


Fig. 31

## 2. Rolling Jack:

- A. Adjust rolling jack telescopic ends until roller rests on runway track rail. Make sure wheels are on tracks and center rolling jack between runway on end sections.
- B. Place jack on runway track at front and rear with air pump facing ends of runway, Fig. 32.
- C. Recommended operating pressure 100-120 psi. (689-827 kPa).
- D. Attach rubber stop see Fig. 32.

## 3. Internal Air Line: (Kit Available)

This kit equips this lift with an internal airline that provides air to both rolling jacks and extra access point for air driven tools (Quick Disconnect Coupler), Fig. 33. All internal air lines are factory assembled.

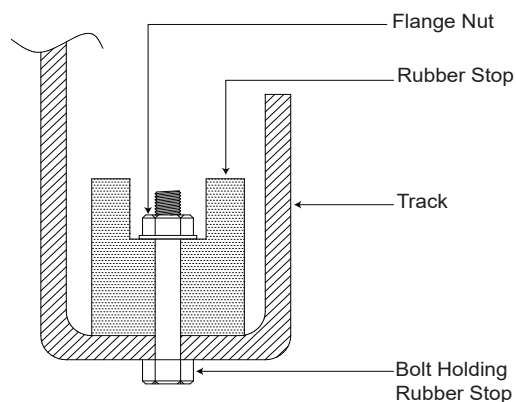
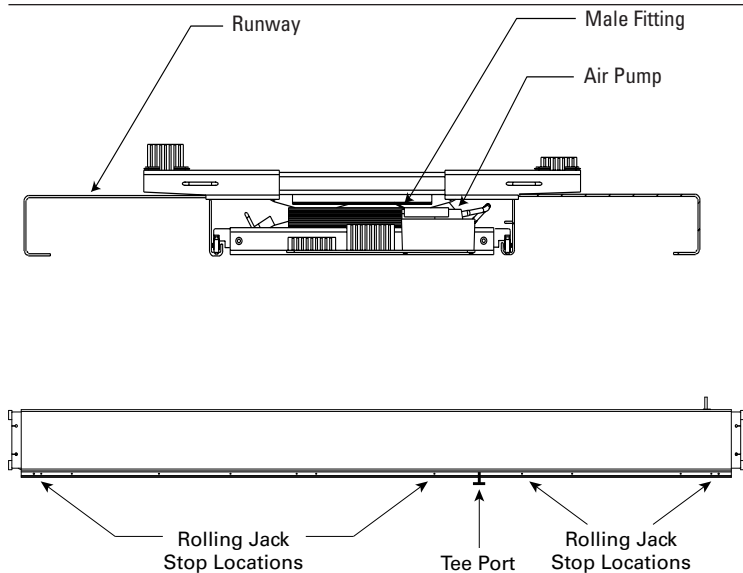


Fig. 32

Attach rubber bridge stops to 9.5mm holes 14" (356mm) off branch tee port. Insert M6-35 bolt up through runway and stop. Attach M6 nut and 6mm flat washer to top of stop.

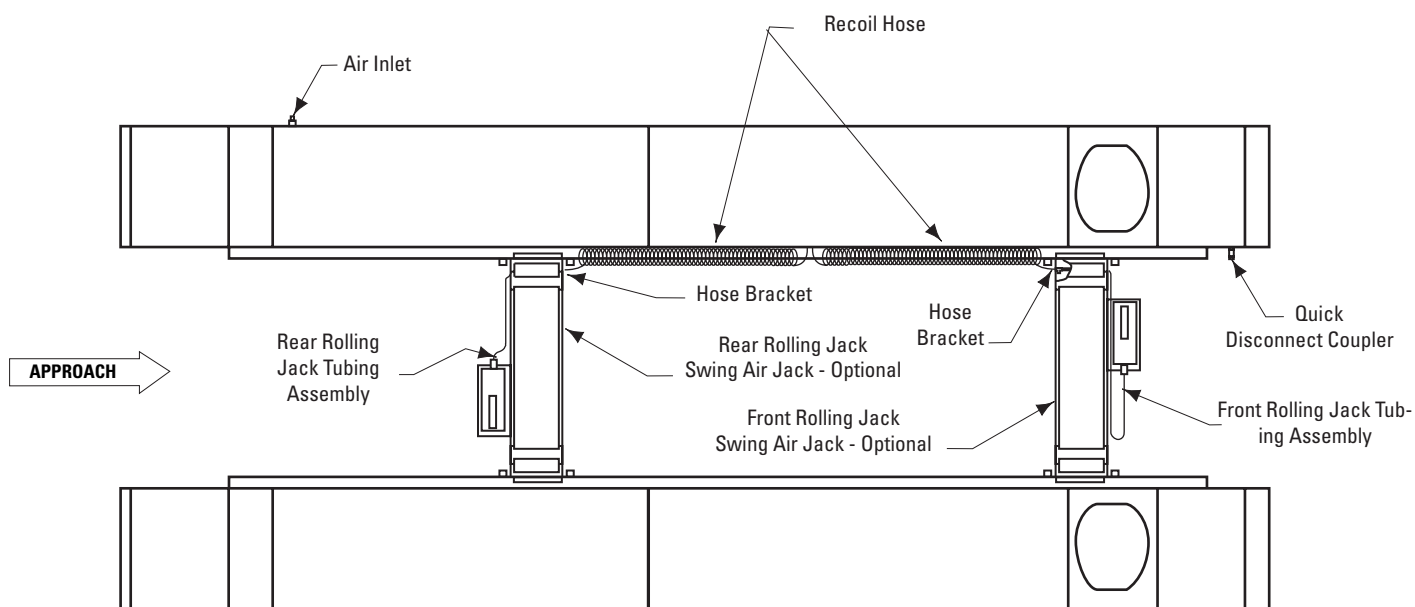


Fig. 33

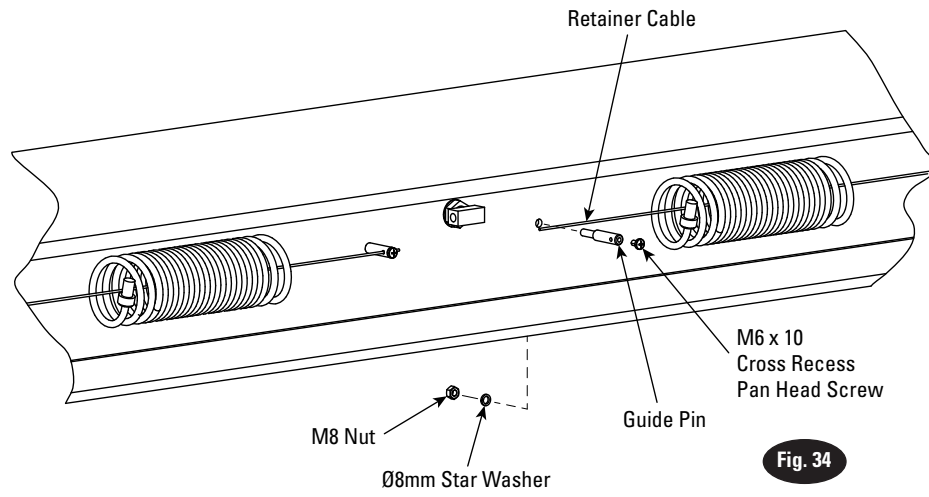
#### 4. Rear Recoil Hose Installation:

- A. Attach retainer brackets for the rear recoil hose with M8 x 30 Lg. hex cap screw, flat washer, lock washer and nut, Fig. 34.
- B. Insert retainer cable through coils of recoil hose, Fig. 34. Run a 1/4"-20NC hex nut down onto each end of retainer cable. Insert each end of cable into retainer brackets. Secure each cable end with another 1/4"-20NC hex nut. Tighten jam nuts, Fig. 34.
- C. Connect one end of provided rear recoil hose to bulkhead T-fitting at midpoint of runway. Connect other end of recoil hose to coupling welded on rolling jack, Fig. 35 and 37.
- D. Connect elbow end of rolling jack tubing assembly to air pump and male end to the coupling, Fig. 35 and 37.

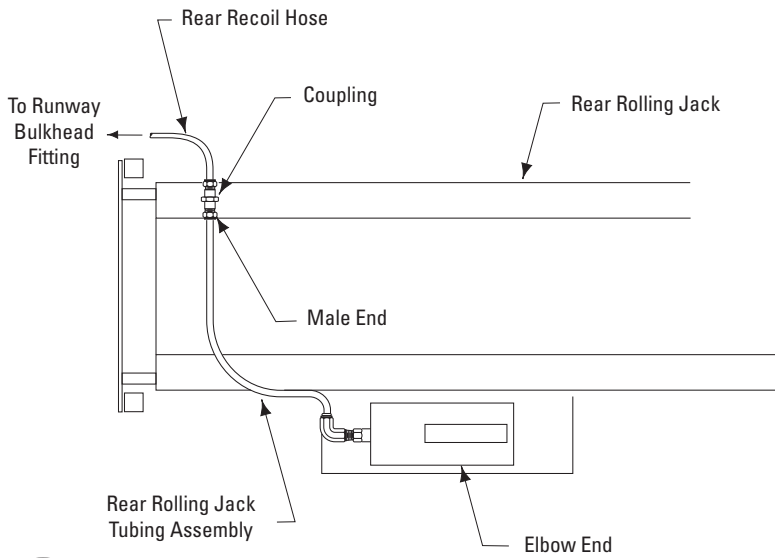
#### 5. Front Recoil Hose Installation:

- A. Insert retainer cable through coils of recoil hose, Fig. 34. Connect one end of recoil hose to coupling welded on rolling jack, Fig. 37 and 38.
- B. Connect other end of front recoil hose to bulkhead T-fitting in center of runway.
- C. Connect elbow end of rolling jack tubing assembly to air pump, and male end to the coupling, Fig. 37 and 38.

**Note:** Cut air line tubing with sharp blade to length as required. Tubing must be cut square with no burrs. To assemble air line tubing into fitting, use firm, manual pressure to push tubing into fitting until it bottoms, (see below). If removal of the air line tubing from the fitting is ever required, hold Push Sleeve in (against fitting) and, at the same time, pull out on tubing.

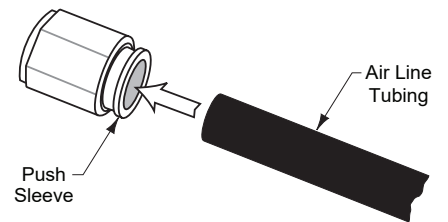


**Fig. 34**

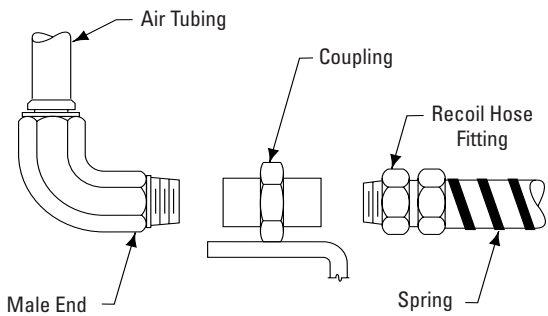


**Fig. 35**

**REAR ROLLING JACK TO RECOIL AIR HOSE**

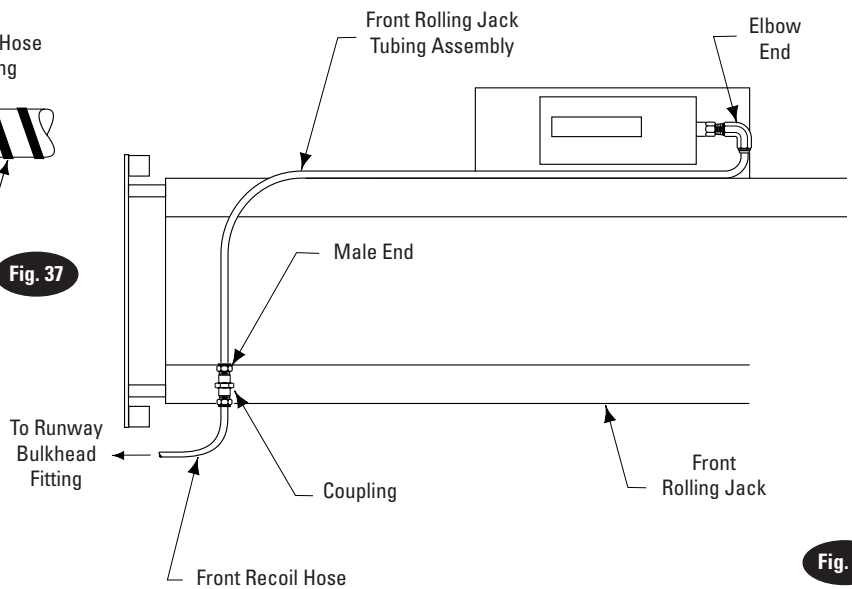


**Fig. 36**



**COUPLING ON ROLLING JACK**

**Fig. 37**



**Fig. 38**

**FRONT ROLLING JACK TO RECOIL AIR HOSE**

**1. Upon completion** of the lift, the lift is to be operated to assure proper function. Observe for locks operating in all locking positions, each side lifts equally, hydraulics do not leak, all electrical controls function as labeled, all pneumatics are functional and leak free, ramps rotate freely (if applicable), and proper clearances with all items in bay have been maintained.

Operate the lift with a typical vehicle and observe to assure the same items for proper functioning.







**Vehicle Service Group<sup>SM</sup>**  
2700 Lanier Drive  
Madison, IN 47250, USA  
1-800-640-5438  
[www.vsgdover.com](http://www.vsgdover.com)



© **Vehicle Service Group<sup>SM</sup>**  
All Rights Reserved. Unless otherwise  
indicated, **Vehicle Service Group<sup>SM</sup>**,  
and all other trademarks are property  
of Dover Corporation and its affiliates.