



AR022

(000 Series & 100 Series) Four Post Surface Mounted Lift

Capacity 22,000 lbs. (9,979 kg.)

9,000 lbs. (4,082 kg.) Front Bridge

15,000 lbs. (6,804 kg.) Rear Bridge

135" (342.9 cm) Wheelbase Length



**I
N
S
T
A
L
L
A
T
I
O
N

I
N
S
T
R
U
C
T
I
O
N
S**

LP20673

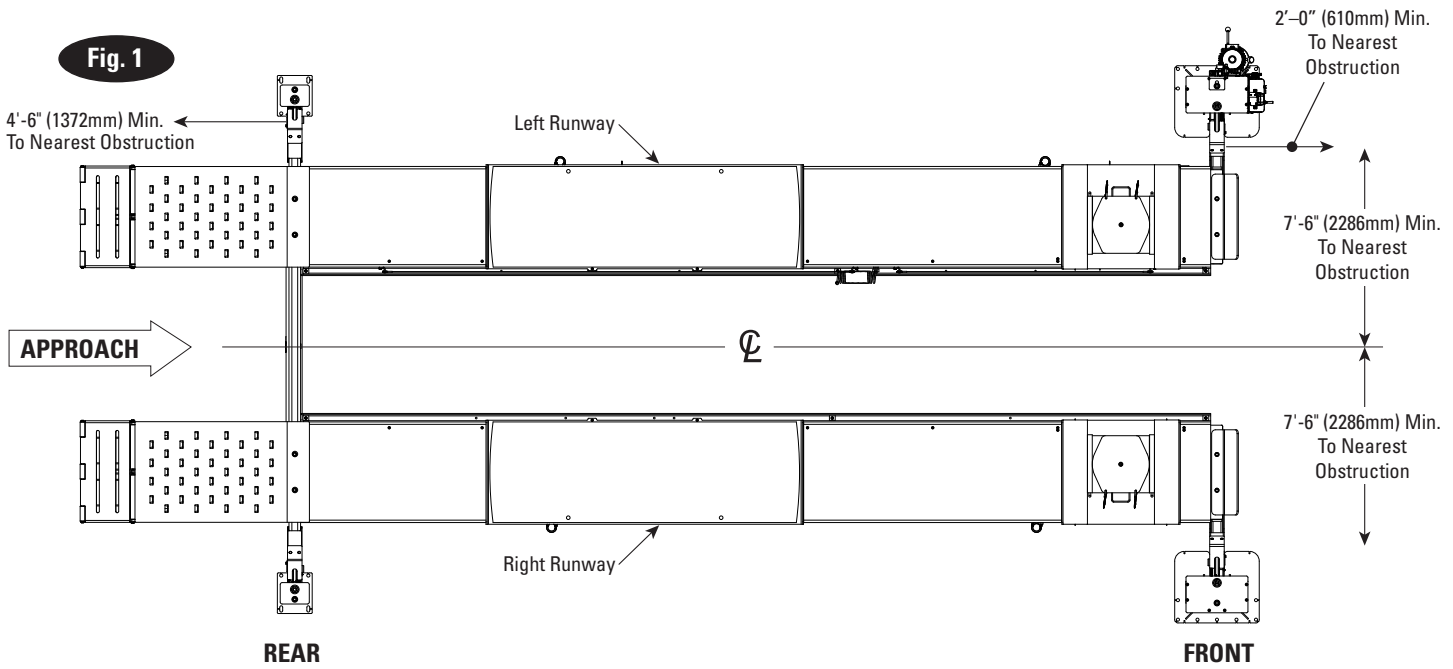

Read and understand these instructions completely before proceeding with lift installation.

1. Lift Location: Use architects plan when available to locate lift. Fig. 1 shows dimensions of a typical bay layout. Lift floor area should be level.

⚠ WARNING DO NOT install on asphalt or other similar unstable surface. Columns are supported only by anchors in floor

2. Ceiling or Overhead Clearance: Must be 110" (2794mm) plus height of tallest vehicle.

3. Estimating Column Shim requirements: In the following section, the terms "highest" and "lowest" refer to elevation of floor.

- Mark locations where lift columns will be positioned in bay.
- Place target on floor at column positions (NOT on column base plates) and record readings, Fig. 2.
- Find the highest of the four locations. Find the difference between the reading at each of the remaining three columns and the highest reading.
- The difference is the estimated amount of shim thickness needed at each column.

Note: Maximum shim thickness is 1/2" (13mm) per column using shims and anchors provided with lift. Shim thickness of 2" (51mm) is possible by using optional shim kit and longer anchors. Contact your authorized Rotary Parts Distributor for ordering information.

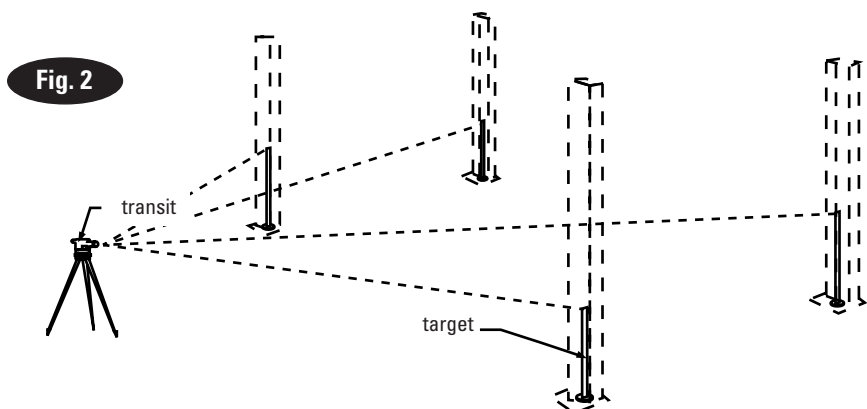

Note: Target is positioned on floor at planned column positions (NOT on column base plates).

Dimension at highest position minus other position equal shim thickness required

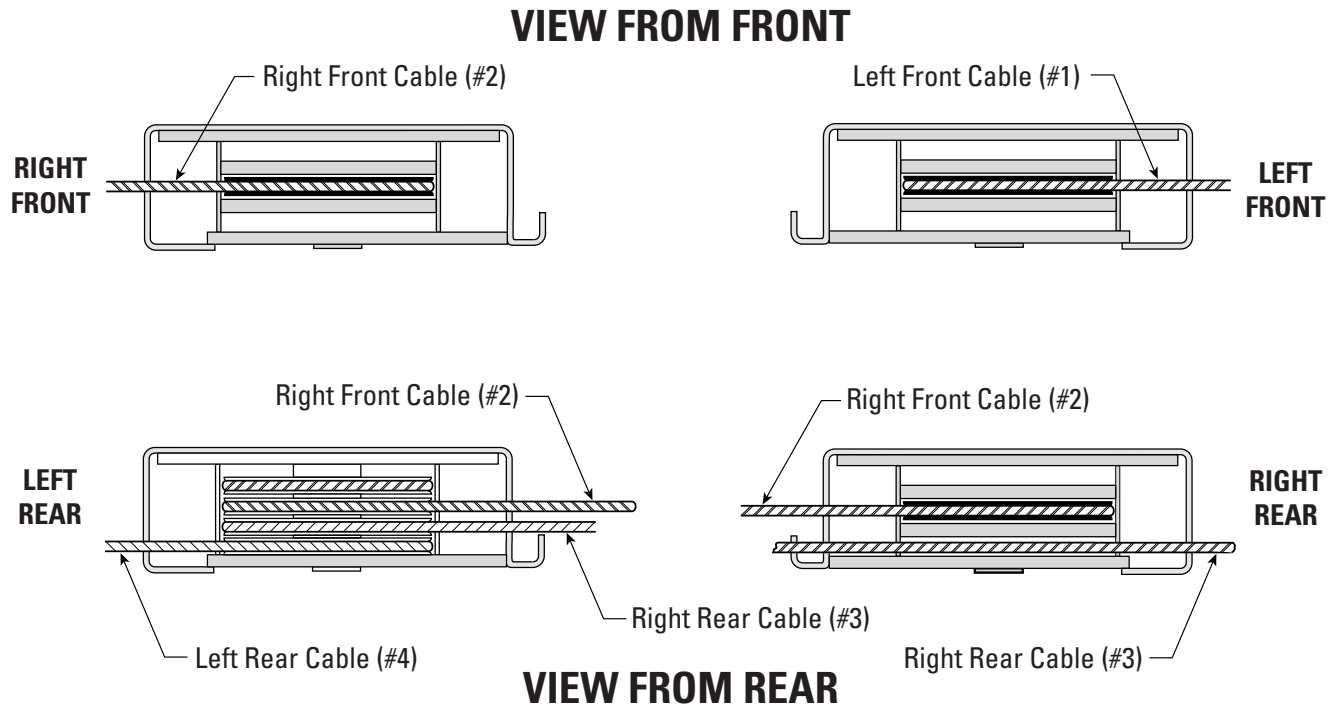

4. Attaching Runways to Rear Yoke:

- A. Determine direction of approach in bay.
- B. Position left runway in bay with hydraulic cylinder hose connection to front of bay. Cables and sheaves are pre-assembled in left runway but only sheaves are installed in the right runway. Runway needs to be up off the floor so shipping restraints can be removed from cable ends, air and hydraulic lines, and cylinder rod. Pull cable ends, air, and hydraulic lines out for assembly.
- C. Position rear yoke at end of runways. The opening in the side of the yoke should be lined up with the cable sheaves in the runway ends. Feed cable ends through yoke openings. Be sure cables are not crossed inside yoke. Feed cable #2 through right runway, Fig. 3 and 4. Make sure cables are in proper sheave grooves, Fig. 3. Route lock and rear steer lock air lines in rear yoke at this time, Fig. 31.

Fig. 4

ARO22 CABLE ROUTING

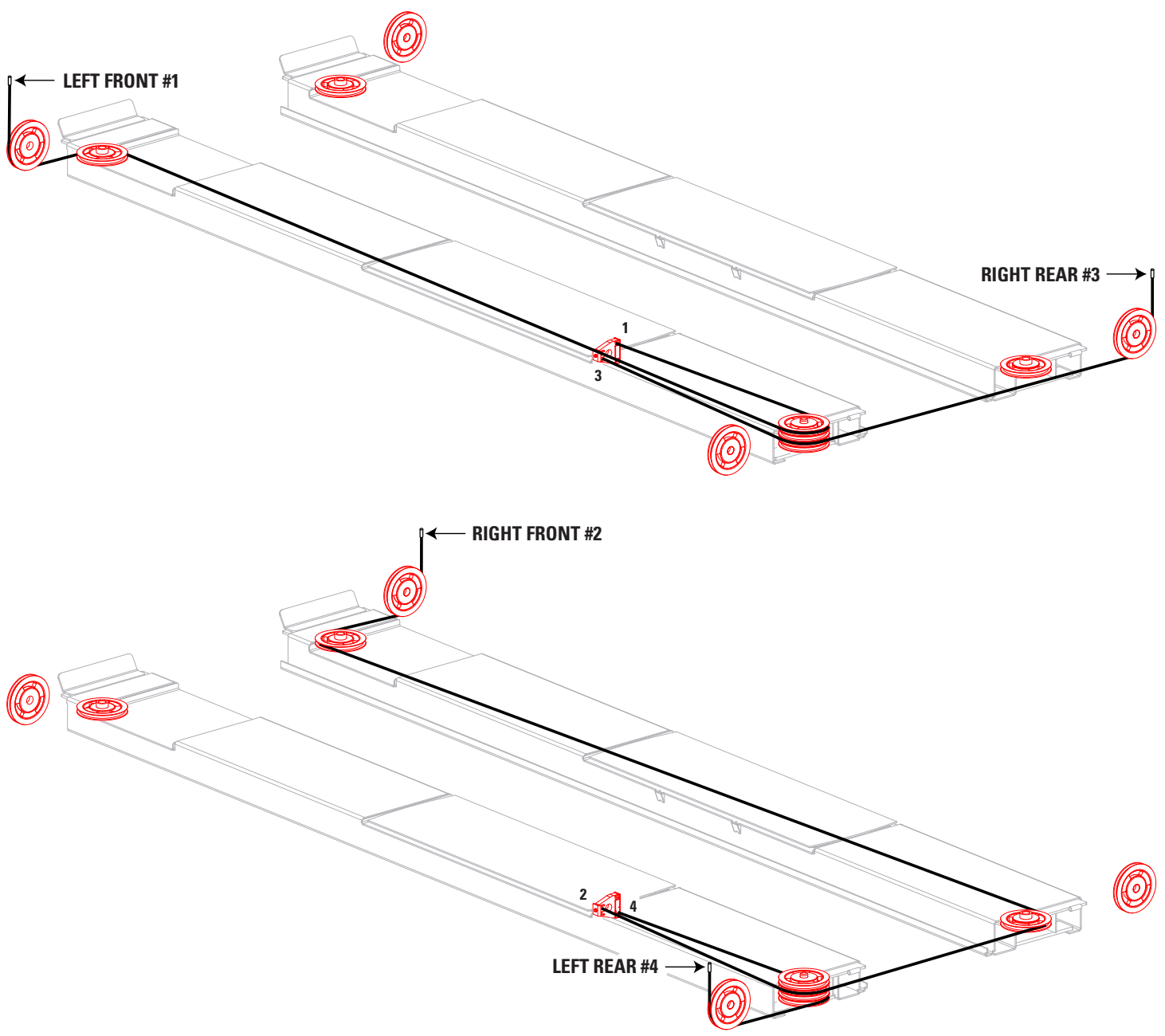

- D. With the openings in the rear yoke tubes side lined up with the runway ends, align the four (4) holes in the top of the yoke tubes with the slots in the runway end plates. Push each runway against metal tab on yoke. Bolt runways to the rear yoke using four 1/2"-13 hex flange bolts, Fig. 5.

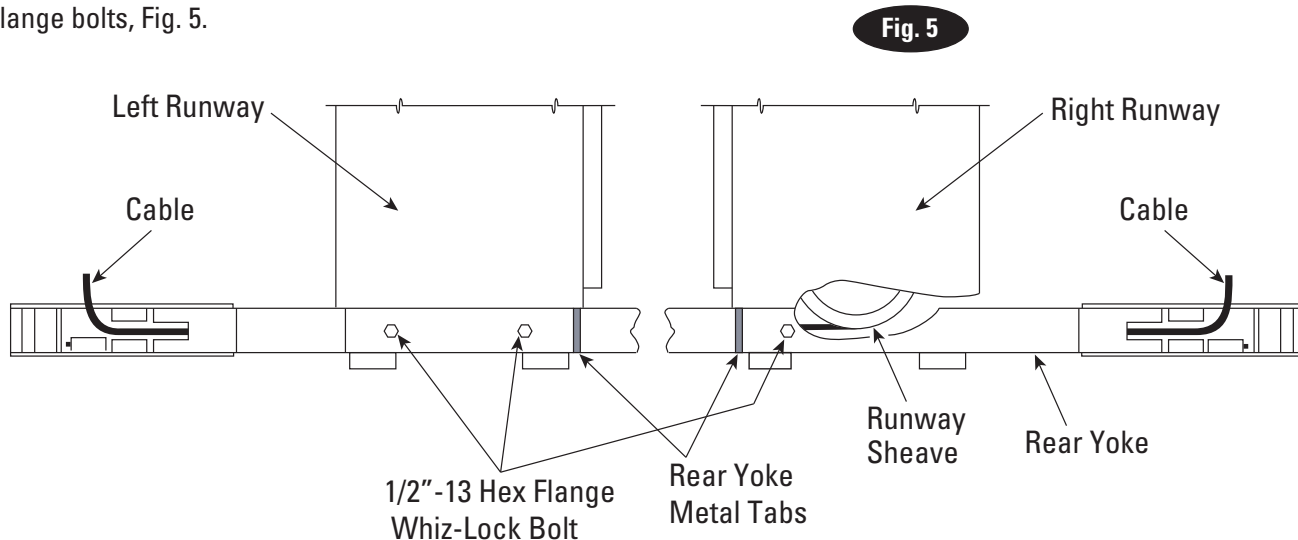

5. Rear Yoke and Column:

- A. Place the rear column at the left corner of the lift. Position remaining rear column.
 B. Thread the jam nut down the threaded stud of the latch bar as far as possible.
Note: latch bars are shipped installed in columns. Thread the adjustment nut up the threaded stud, adjustment nut threads should be fully engaged, Fig. 6. Repeat for other columns.

- C. Install rear yoke end sheaves and sheave spacers. A sheave spacer is placed on each side of the sheave, Fig. 7. Install sheave pin and retain with 5/16"-18NC x 1/2" HHCS bolt, Fig. 7.

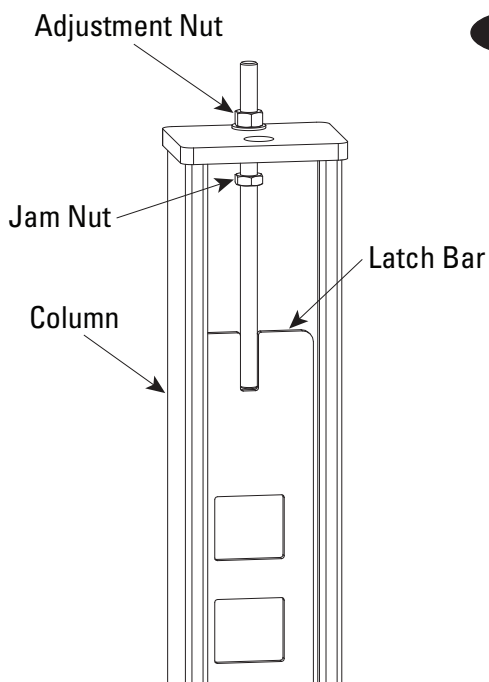

Fig. 6

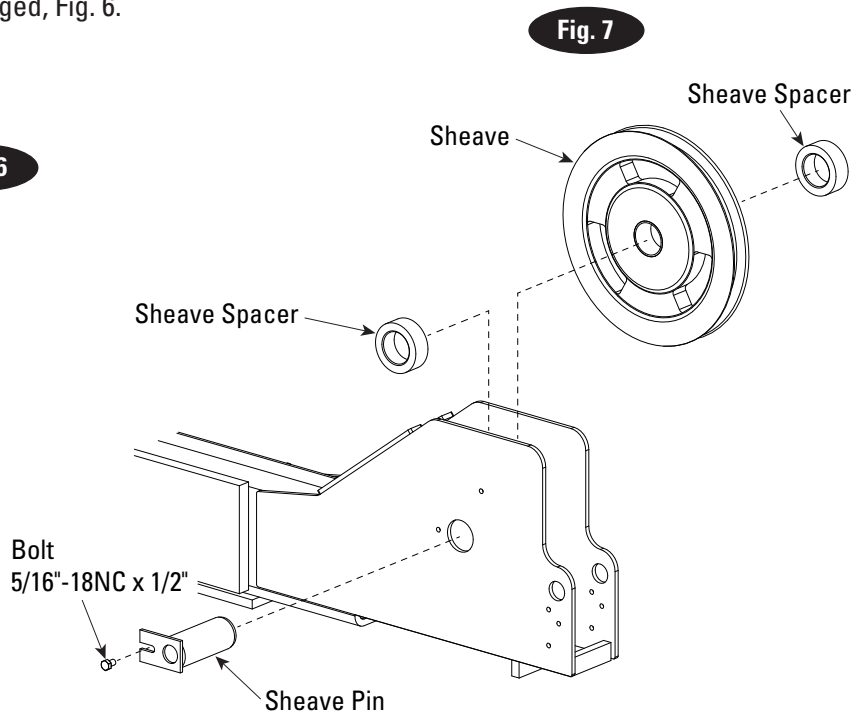
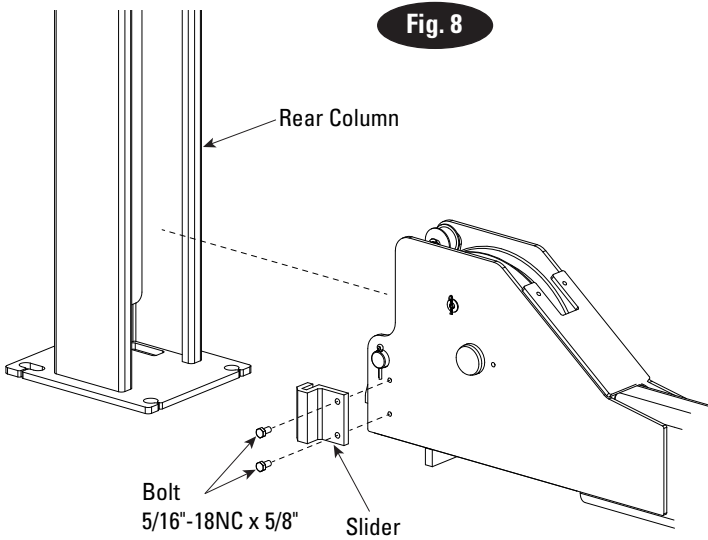
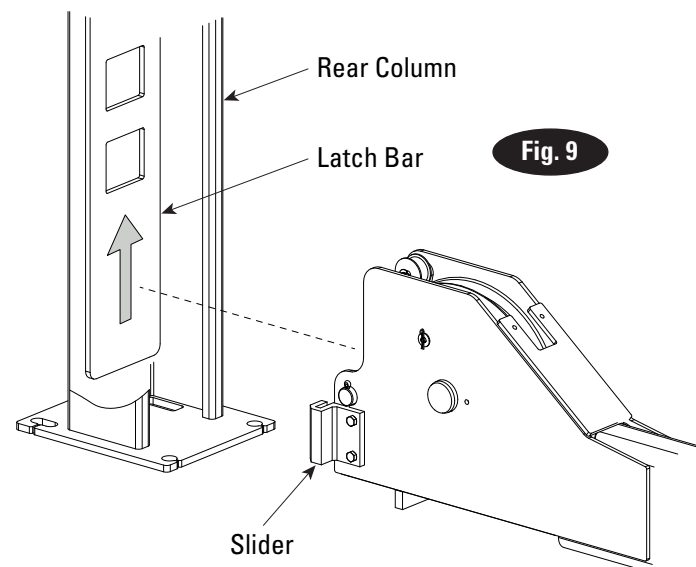

Fig. 7

D. Start yoke end into the column, allowing slider bolt holes to stay exposed. Attach sliders onto each side of the yoke end with 5/16"-18NC x 5/8" bolts, Fig. 8. When both sliders are attached, push column toward yoke end until sliders touch latch bar.



E. Raise latch bar above sliders and move column toward yoke until the sliders contact the back of the column. It may be necessary to raise column up, using two more more individuals, so latch bar clears sliders. Lower the latch bar into the sliders, Fig. 9, making sure latch bar is all the way down into the sliders. Tighten latch bar jam nut against column top plate. The latch bar should engage the sliders for at least 1" (25mm) when the lift is completely lowered. Repeat this procedure for each rear yoke end and column.



F. **IMPORTANT** Be sure cable is isolated in the sheave groove. Attach cable to column top plate with 1-1/8" washer, 1-1/8"-7NC hex nut, and 1-1/8"-7NC jam nut, Fig. 10. Install rear yoke cover on each yoke end using 1/4"-14NC x 3/4" Lg. bolts, Fig. 10.

Note: Cable routing diagram is available in Fig. 4.

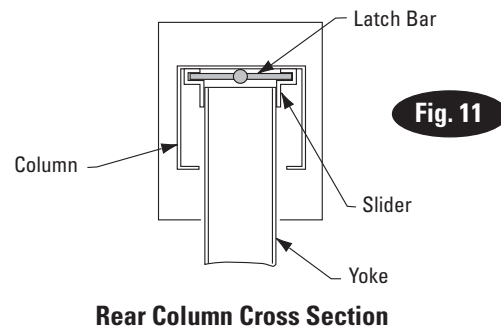
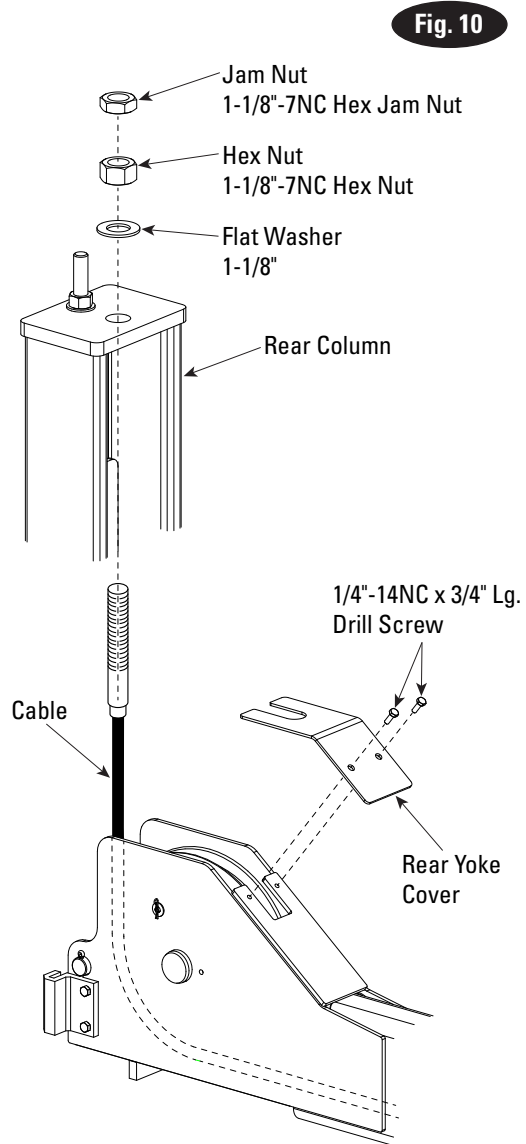

IMPORTANT Route airlines to air locks before installing sheaves.

- 6. **Front Sheave Install:** Install sheaves and sheave spacers. Place sheave spacer on each side of the sheave, Fig. 12. Fasten sheave pin with 5/16"-18NC x 1/2" Lg. HHCS. Be sure cable is located in the sheave groove.
- 7. **Cable Install:** Attach each cable to column top plate with 1-1/8" nut, 1-1/8" jam nut, and 1-1/8" washer, Fig. 12.
Install steel Front Yoke Cover on each yoke end, Fig. 12.

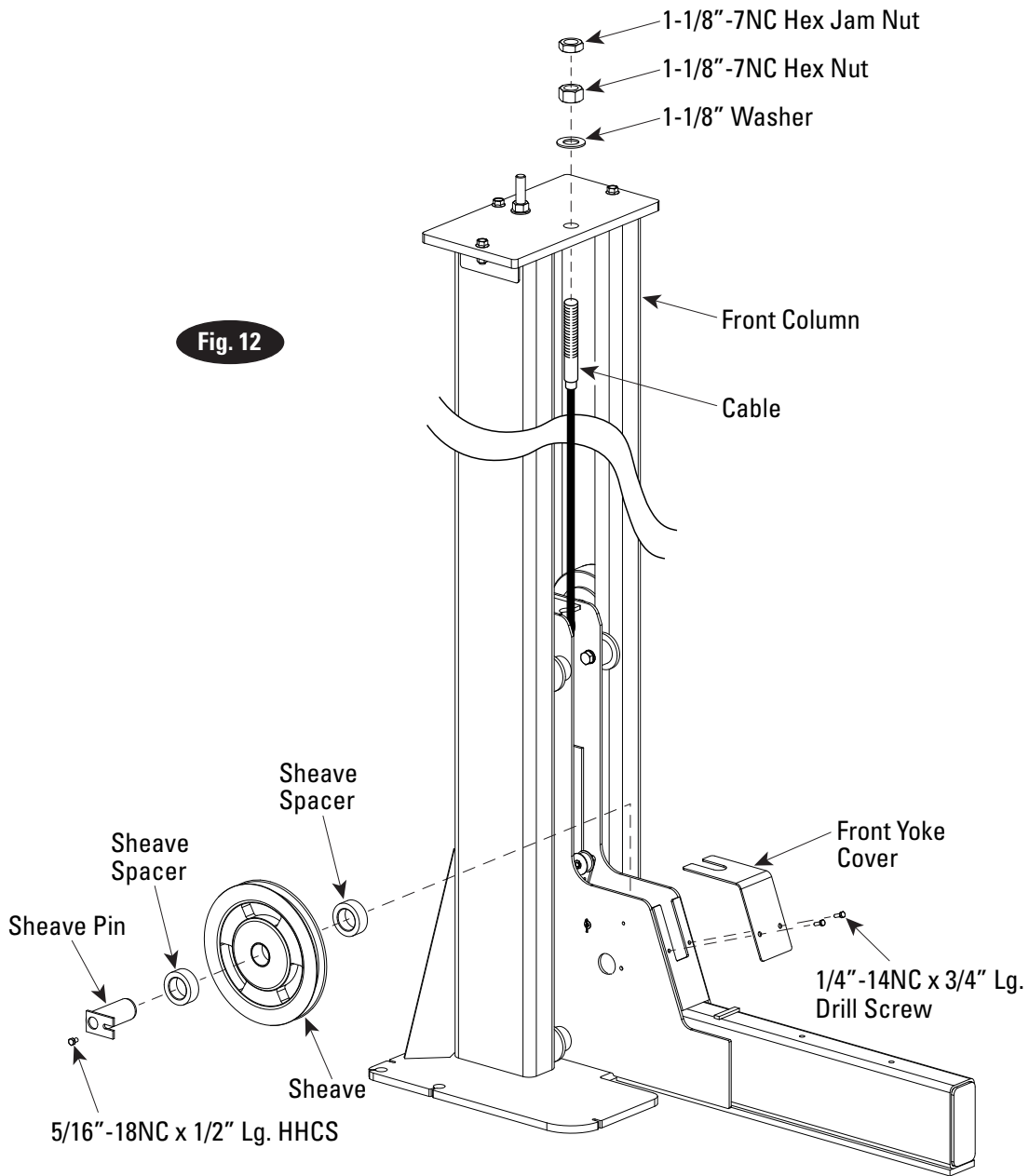

8. Concrete and Anchoring:

- A. Square up runways. Adjust runways until diagonals are equal. Check lift location in the bay. Check dimensions side-to-side, equal to within 1/8" (3mm), Fig. 13.
Installation tool S121610 included, Fig. 13.

CAUTION DO NOT install on asphalt or other similar unstable surfaces. Columns are supported only by anchors in floor.

Fig. 13

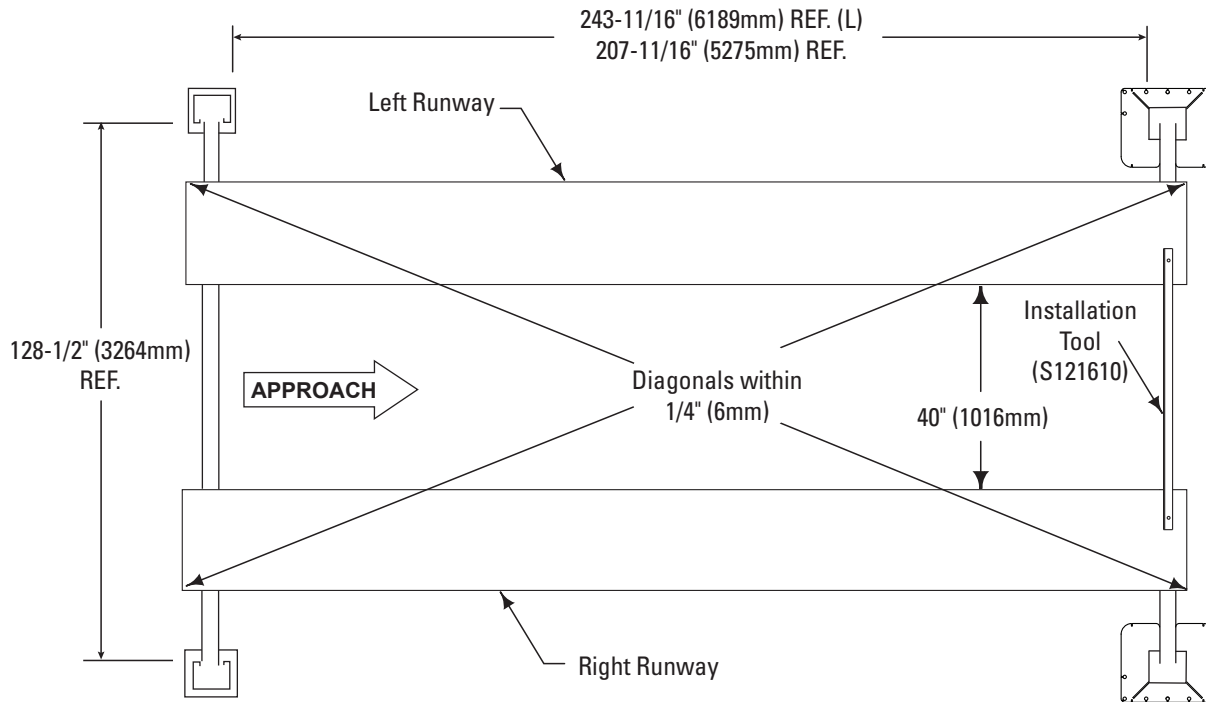

B. Rear Column Install.

1. Move rear column towards yoke until the sliders contact the back of column. Center yoke in column, Fig. 11.
2. Place shims (estimated from Step 3) under each column. Drill four 5/8" (16mm) diameter holes through concrete floor using holes in baseplate as guide, Fig. 14.
3. Insert anchors with washers, Fig. 14. 5/8" anchors must have a minimum anchor embedment of 2-3/4" (70mm). If the top of the anchor exceeds 1-1/2" (38mm) above the floor grade, you DO NOT have enough embedment.
4. Tighten 5/8" anchor bolts to an installation torque of 60 ft-lbs. (81 Nm). Shim thickness MUST NOT exceed 1/2" (13mm) when using the standard anchors provided with the lift. Check columns for plumb. Re-shim if necessary. Repeat for other column. If anchors do not tighten to required installation torque, replace concrete under each column base with a 4' x 4' x 6" (1219 x 1219 x 152mm) thick 3000 PSI (20684 kPa) minimum concrete pad keyed under and flush with the top of existing floor. Let concrete cure before installing lifts and anchors.

C. Front Column Anchoring:

1. If necessary, readjust runways until diagonals are equal. Hold runway spacing at 40" (1016mm).
2. Drill six 3/4" (19mm) holes through concrete floor using holes in baseplate as guide.
3. Insert anchors with washers, Fig. 15. 3/4" anchors must have a minimum anchor embedment of 3-1/4" (83mm). If the top of the anchor exceeds 2-1/4" (57mm) above the floor grade, you DO NOT have enough embedment.
4. Tighten 3/4" anchor bolts to an installation torque of 110 ft-lbs. (149 Nm). Shim thickness MUST NOT exceed 1/2" (13mm) when using the standard anchors provided with the lift. Check columns for plumb. Re-shim if necessary. Repeat for other column. If anchors do not tighten to required installation torque, replace concrete under each column base with a 4' x 4' x 6" (1219 x 1219 x 152mm) thick 3000 PSI (20684 kPa) minimum concrete pad keyed under and flush with the top of existing floor. Let concrete cure before installing lifts and anchors.

ANCHORING

Rear Column

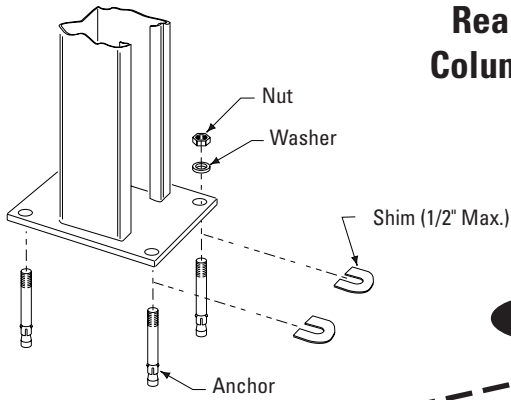

Fig. 14

Front Column

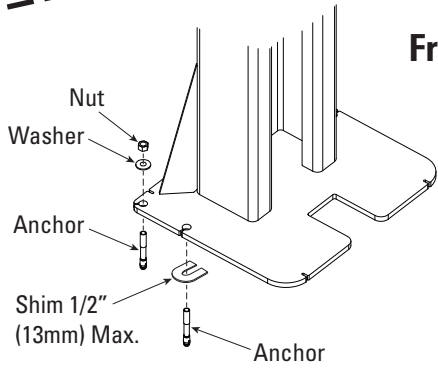
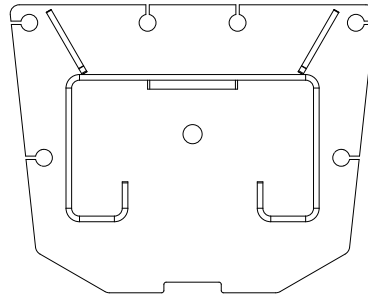

Fig. 15

**000 Series
Front Baseplate
(6) Anchors**



**100 Series
Front Baseplate
(7) Anchors
(Shown in Fig. 15)**

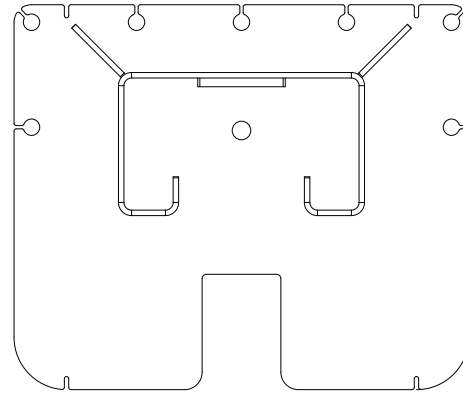
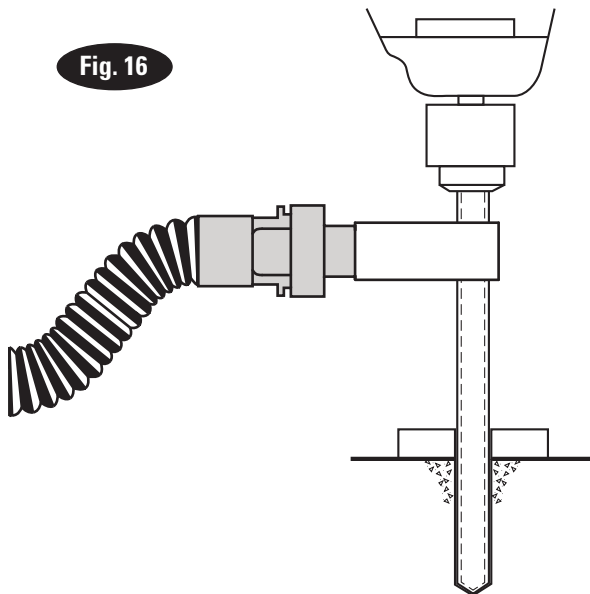

Fig. 16



Drill holes using carbide tipped masonry drill bit per ANSI B212.15. Construction dust collected per OSHA 29 CFR 1926.1153.



Run nut down just below impact section of bolt. Drive anchor into hole until nut and washer contact base.

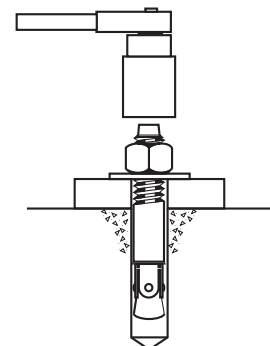

Tighten nut with Torque wrench. See Anchoring Requirements Table.

CONCRETE AND 3/4" ANCHORING REQUIREMENTS								
Anchor:	Min Concrete Thickness	Min Edge Distance	Min Anchor Embedment	Installation Anchor Torque (ft-lbs)	Min Concrete PSI Strength - For All Standards	Concrete pad Size If Concrete Does Not Meet Requirements	Maintenance Torque Values** (ft-lbs)	SEISMIC
Hilti Kwik Bolt I (3/4" x 5-1/2")	4-1/4" (108mm)	6-1/4" (159mm)	3-1/4" (83mm)	110 (149Nm)	3000 (20684 kPa)	4'x4'x8" (1219 x 1219 x 152mm)	65 (88Nm)	Varies by location consult with your structural engineer and manufacturer's representative.
DeWalt Power-Stud+SD1 (3/4" x 5-1/2")	4-1/4" (108mm)	6-1/4" (159mm)	3-1/4" (83mm)	110 (149Nm)	3000 (20684 kPa)	4'x4'x8" (1219 x 1219 x 152mm)	65 (88Nm)	
Hilti HY200 Epoxy (with HAS threaded rod) 3/4" Dia.	5" (134mm)	2 1/4" (57mm)	3-1/2" (89mm)	100 (135Nm) / less than 2-1/8" edge distance use Torque Value of 30 ft-lbs (41Nm)	3000 (20684 kPa)	4'x4'x8" (1219 x 1219 x 152mm)	N/A	
<p align="center">*The supplied concrete fasteners meet the criteria of the American National Standard "Automotive Lifts - Safety Requirements for Construction, Testing, and Validation" ANSI/ALI ALCTV: 2017, or latest edition, and the lift owner is responsible for all charges related to any additional anchoring requirements as specified by local codes. Contact customer service for further information at: 800.640.5438</p>								

CONCRETE AND 5/8" ANCHORING REQUIREMENTS								
Anchor:	Min Concrete Thickness	Min Edge Distance	Min Anchor Embedment	Installation Anchor Torque (ft-lbs)	Min Concrete PSI Strength - For All Standards	Concrete pad Size If Concrete Does Not Meet Requirements	Maintenance Torque Values** (ft-lbs)	SEISMIC
Hilti Kwik Bolt I (5/8" x 4-3/4")	3-5/8" (92mm)	7" (178mm)	2-3/4" (70mm)	60 (81Nm)	3000 (20684 kPa)	2'x2'x8" (610 x 610 x 203mm)	50 (68Nm)	Varies by location consult with your structural engineer and manufacturer's representative.
DeWalt Power-Stud+SD1 (5/8" x 4-3/4")	3-5/8" (92mm)	6-1/4" (159mm)	3-1/4" (83mm)	60 (81Nm)	3000 (20684 kPa)	2'x2'x8" (610 x 610 x 203mm)	50 (68Nm)	
Hilti HY200 Epoxy (with HAS threaded rod) 5/8" Dia.	5" (127mm)	2 1/4" (57mm)	3-1/2" (89mm)	60 (81Nm) / less than 2" (51mm) edge distance use Torque Value of 18 ft-lbs (24Nm)	3000 (20684 kPa)	2'x2'x8" (610 x 610 x 203mm)	N/A	
<p align="center">*The supplied concrete fasteners meet the criteria of the American National Standard "Automotive Lifts - Safety Requirements for Construction, Testing, and Validation" ANSI/ALI ALCTV: 2017, or latest edition, and the lift owner is responsible for all charges related to any additional anchoring requirements as specified by local codes. Contact customer service for further information at: 800.640.5438</p>								

9. Runway Leveling:

- A. Use an engineer's automatic level (transit). Locate the Level at a convenient location in the shop that allows an unobstructed view of all four corners of the lift's runways. Follow the Level manufacturer's instructions for proper setup. Be sure it is adjusted level in all directions. Readjust level if it or tripod is bumped or disturbed.
- B. Make sure yoke tubes rest on column base plate.
- C. First place the Level target at the highest corner of the lift. Place it on the runway center line within 6" (152mm) of yoke tube, whichever one is located over highest point. This will be referred to as target "A" position. Beginning with target "A" position, Fig. 18, sight the Level to the target and mark the number or the graduation on the inch scale of the target that aligns to the crosshairs of the Level, Fig. 17.

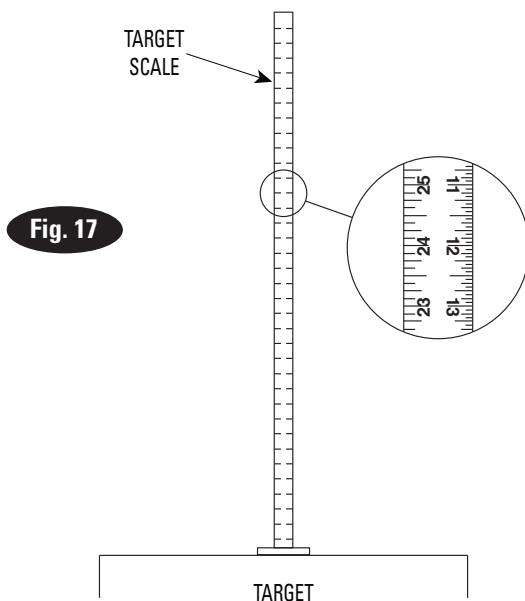

RUNWAYS SHOULD BE LEVEL MAXIMUM TOLERANCE SIDE TO SIDE AND FRONT TO REAR 1/16" (1.6MM)

Note: Use a pencil, marking pen or attach a paper clip on to the target scale at the crosshair reference.

- D. Next, move the target and place it on the runway at point "B", Fig. 18. Rotate the Level and focus on the target scale. Adjust the column at "B" using shims under base plate, Figs. 14 and 15, until the cross-hairs of Level align to reference mark on the target scale. Repeat for points C and D.

10. Cable Adjustment:

Adjust cable with lift fully lowered. Loosen jam nut and tighten nut on cable stud on top of column until yoke end raises 1/4" (6mm). Back off nut one turn. Retighten jam nut. Repeat for all four cables. Cables must fit in slack cable arm rollers, Fig. 19.

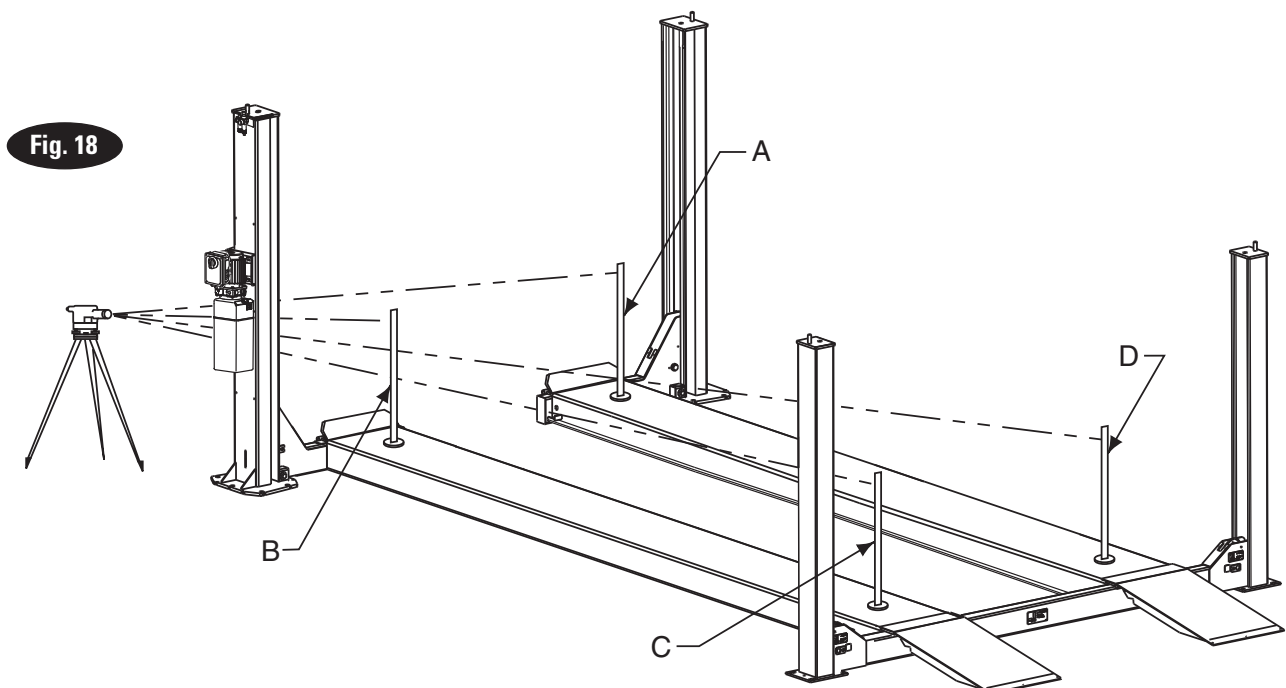
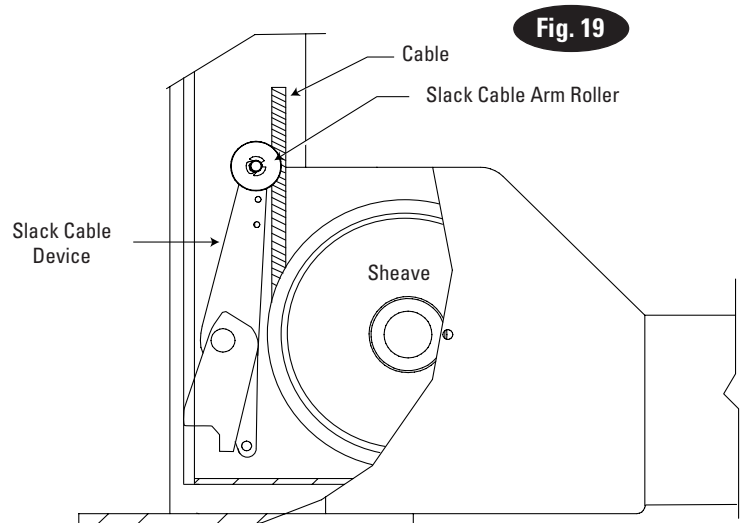

11. Power Unit:

Note: The ARO22 uses VFD (variable frequency drive) technology to maximize raise speed based on vehicle load. The VFD will convert any incoming power to a 3-phase variable frequency motor output. For single phase input, the VFD can be set for 30A or 20A service (30A will result in faster raise times). Refer to wiring diagram for incoming power connections, Fig. 26b.

- A. Attach 5/16"-18NC x 1-1/2" Lg. HHCS to the mounting plate as shown using 5/16" Tooth Washers, Fig. 20.
- B. Attach Power Unit using 5/16"-18NC Hex Flanged WZ Lock Nuts, Fig. 20.

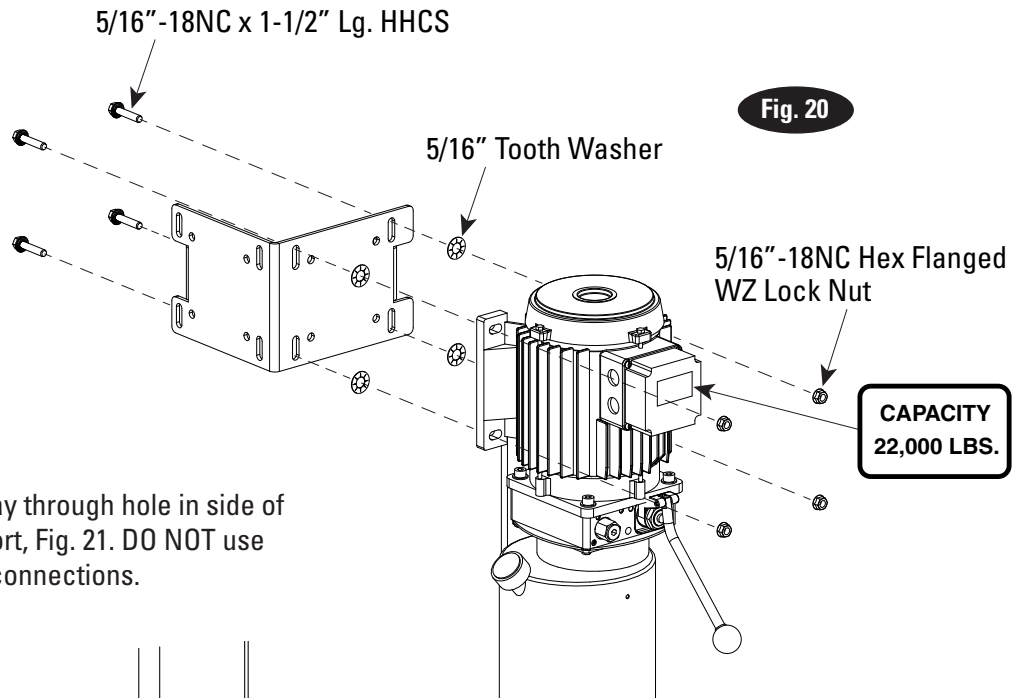

- C. Run hydraulic hose from runway through hole in side of runway to power unit output port, Fig. 21. DO NOT use Teflon tape on hydraulic hose connections.

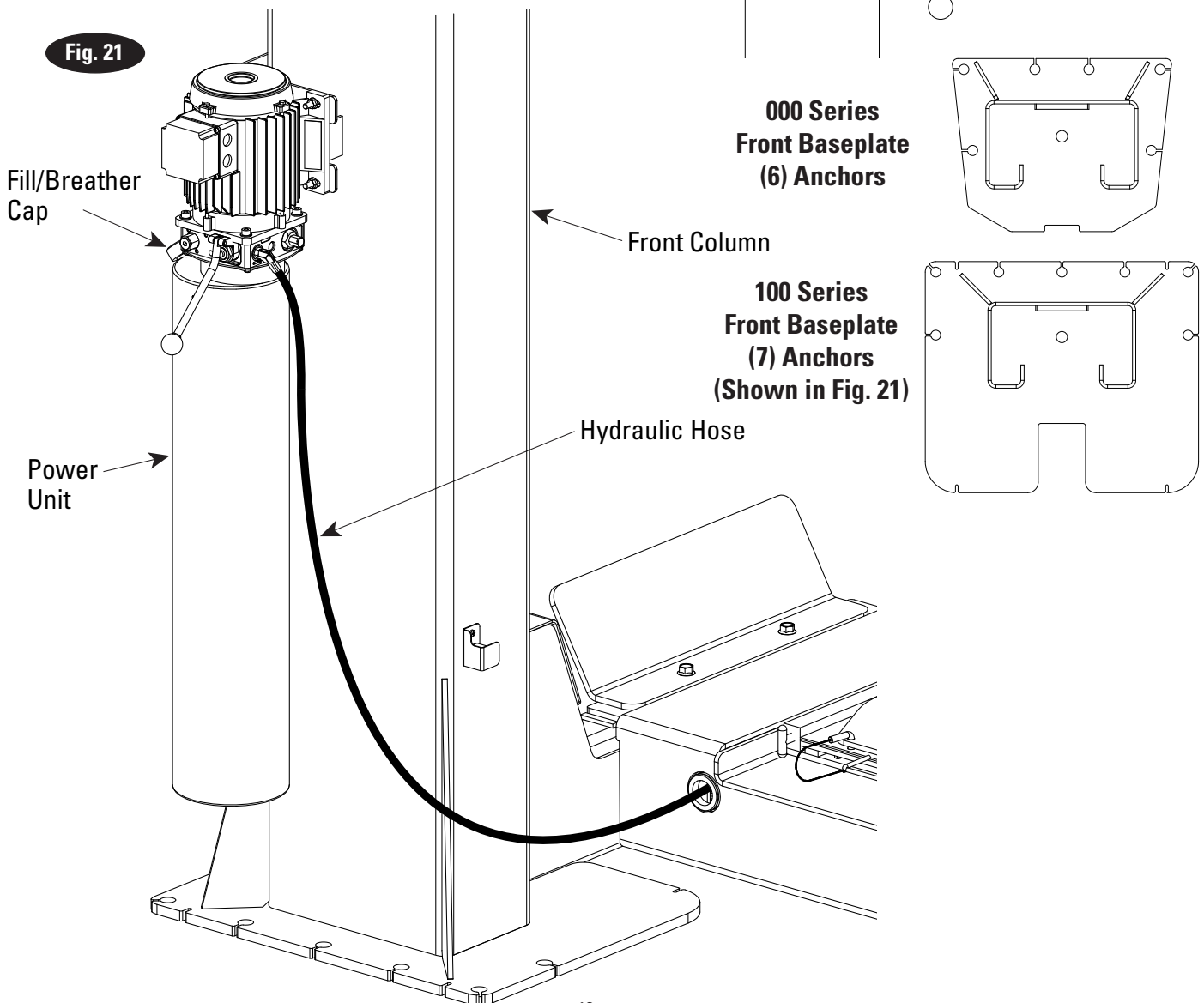

- D. Install and hand tighten elbow to pump until O-ring is seated and elbow is oriented downward at approximately 45°, Fig. 22. Continue to tighten the locknut to 10-15 ft-lbs. (14-20 Nm), or until the nut and washer bottom out against the pump manifold. Clean elbow and hose. Inspect all threads for damage and hose ends to be sure they are crimped. Attach hose to elbow using Flared Fittings Tightening Procedure.

NOTE: You may still be able to rotate the elbow. This is acceptable unless there is seepage at the o-ring. If so, slightly tighten the locknut.

Flared Fittings Tightening Procedure

1. Screw the fitting together finger tight. Then, using the proper size wrench, rotate the fitting 2-1/2 hex flats.

IMPORTANT Flare seat **MUST NOT** rotate when tightening. Only the nut should turn.

2. Back the fitting off one full turn.
3. Again tighten the fittings finger tight; then using a wrench, rotate the fitting 2-1/2 hex flats. This will complete the tightening procedure and develop a pressure tight seal.

CAUTION Overtightening will damage fitting resulting in fluid leakage.

- 12. Electrical:** Route supplied attached motor wire from controller to motor, Fig. 23.

NOTE: VFD is prewired to 20 Amp service. The VFD can be changed to 30 Amp to maximize raise speed, if suitable electrical service is available to the bay (undersized electrical service may cause voltage drops leading to motor stalling). The VFD can be changed to 30A by installing a 2-inch jumper wire between terminals DCM and M2. Jumper wire gauge size is not critical, but 20AWG fits the terminals easily. The VFD must be power cycled to take a new setting.

CAUTION Never operate the motor on line voltage less than 208V. Error codes will occur.

IMPORTANT Use separate circuit for each power unit. Protect each circuit with time delay fuse or circuit breaker. For wiring see Fig. 23. All wiring must comply with NEC and all electrical codes.

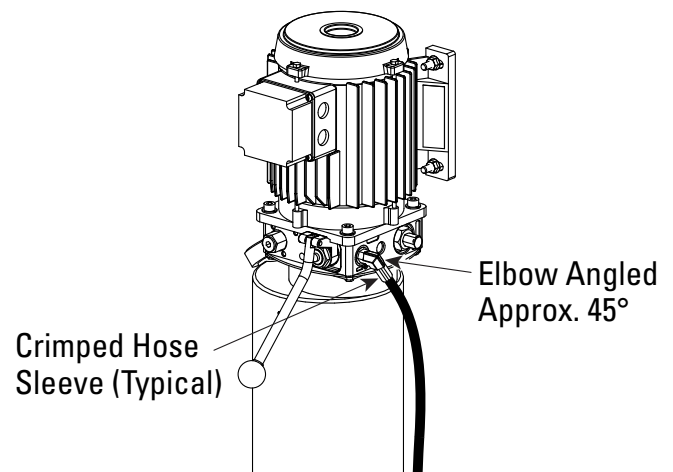

Fig. 22

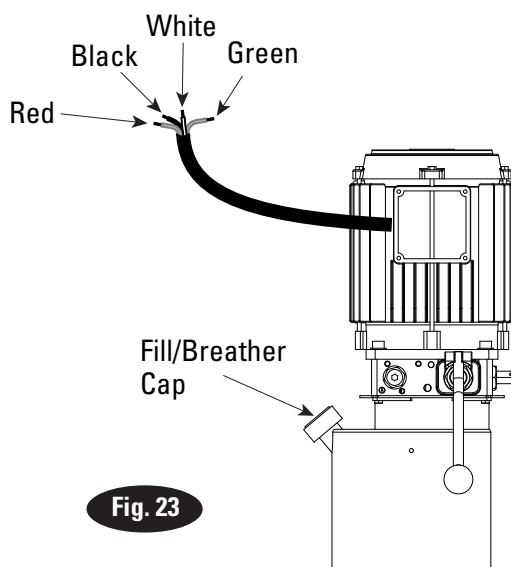
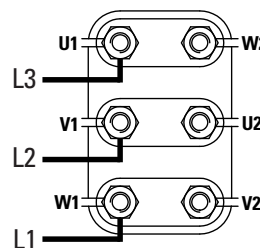

Fig. 23

Three Phase Power Unit

MOTOR OPERATING DATA TABLE - THREE PHASE	
LINE VOLTAGE	RUNNING MOTOR VOLTAGE RANGE
208-240V 50/60Hz.	197-253V

Pin Layouts



NOTE: Motor terminal jumpers may need adjusted for the correct voltage input. Set the motor terminal jumpers as shown for 208-230 VAC.

208-240V
50/60Hz. 3Ø

13. Light Controller Assembly: Have a certified electrician run appropriate power supply to controller, Fig. 26b. Size wire for 30 amp circuit, lift can also be set for 30 amp service, refer to note in wiring diagram. See Motor Operating Data Table.

IMPORTANT Verify ON/OFF switch located at the bottom of the SmartFILL unit is set to ON before replacing cover.

Fig. 24

Install S130427 Top Onto Controller Asm Using (2) 5/16"-18NC x 1/2" HWHCS

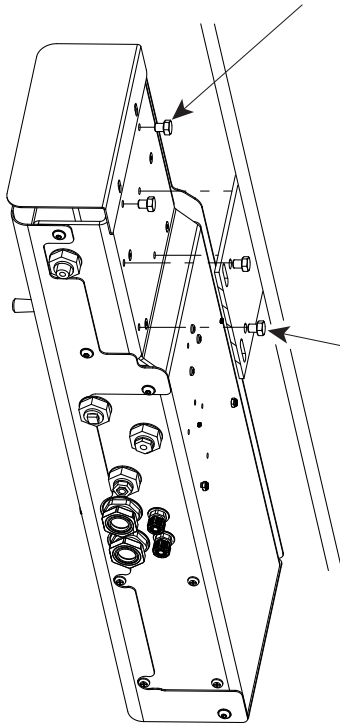

Install S130402/S130455 Controller To PU Column Bracket Using (4) 5/16"-18NC x 1/2" HWHCS

S130459 Terminal Strip

Incoming Power Wires, Green Wire To Green Terminal, White Wire To White Terminal, Black Wire To Black Terminal, Fig. 26b

Fig. 25

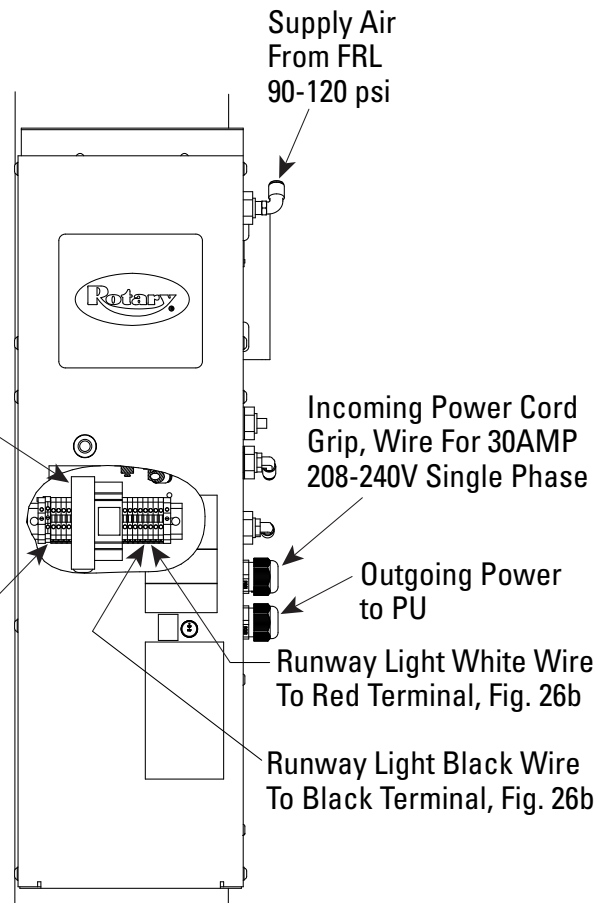

14. Photo Eye w/Supplied Bracket and Lock Light Installation:

1. After installing the controller and running the runway lights to the correct terminals, Fig. 25, install the pre-wired photo eye to the front side of the column with supplied bracket and hardware, Fig. 26.

IMPORTANT

Verify photo eye does not protrude through column. Photo eye should be flush with inside of column.

2. Attach the supplied 3M reflective tape to the side opposite of the photoeye installed above, centering the tape on the beam emitted from the eye, Fig. 26, (eye will have to be powered on to achieve this).

**000 Series
Front Baseplate
(6) Anchors**

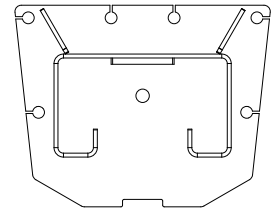

**100 Series
Front Baseplate
(7) Anchors
(Shown in Fig. 26)**

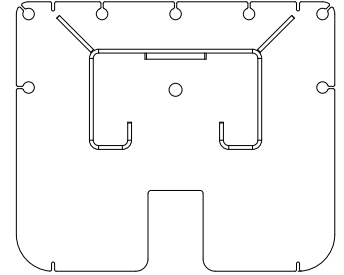
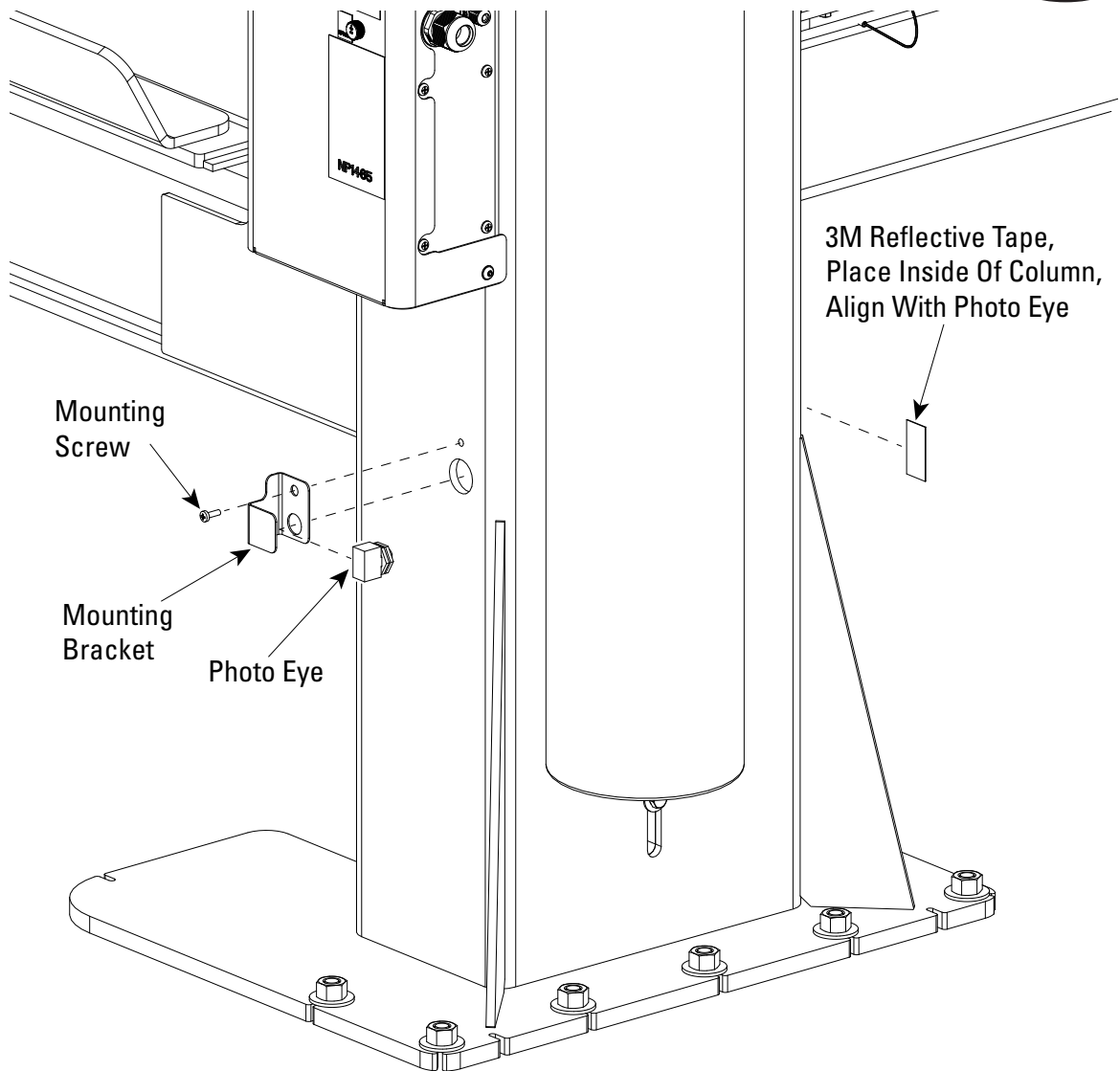

Fig. 26



3. Attach lock light w/bracket to existing hole in column with supplied hardware, 3/8"-16 x 3/4" Lg. HWHCS and 3/8"-16 nylon insert jam nut, Fig. 26a.
4. Attach hydraulic fittings/lines as per lock light supplemental instructions.
5. Wire lock light wires into the smartfill/light controller using the 1/2" npt cord grip, located on the side of controller, to the open L1 & L2 terminal blocks in the light controller, Fig 26b.

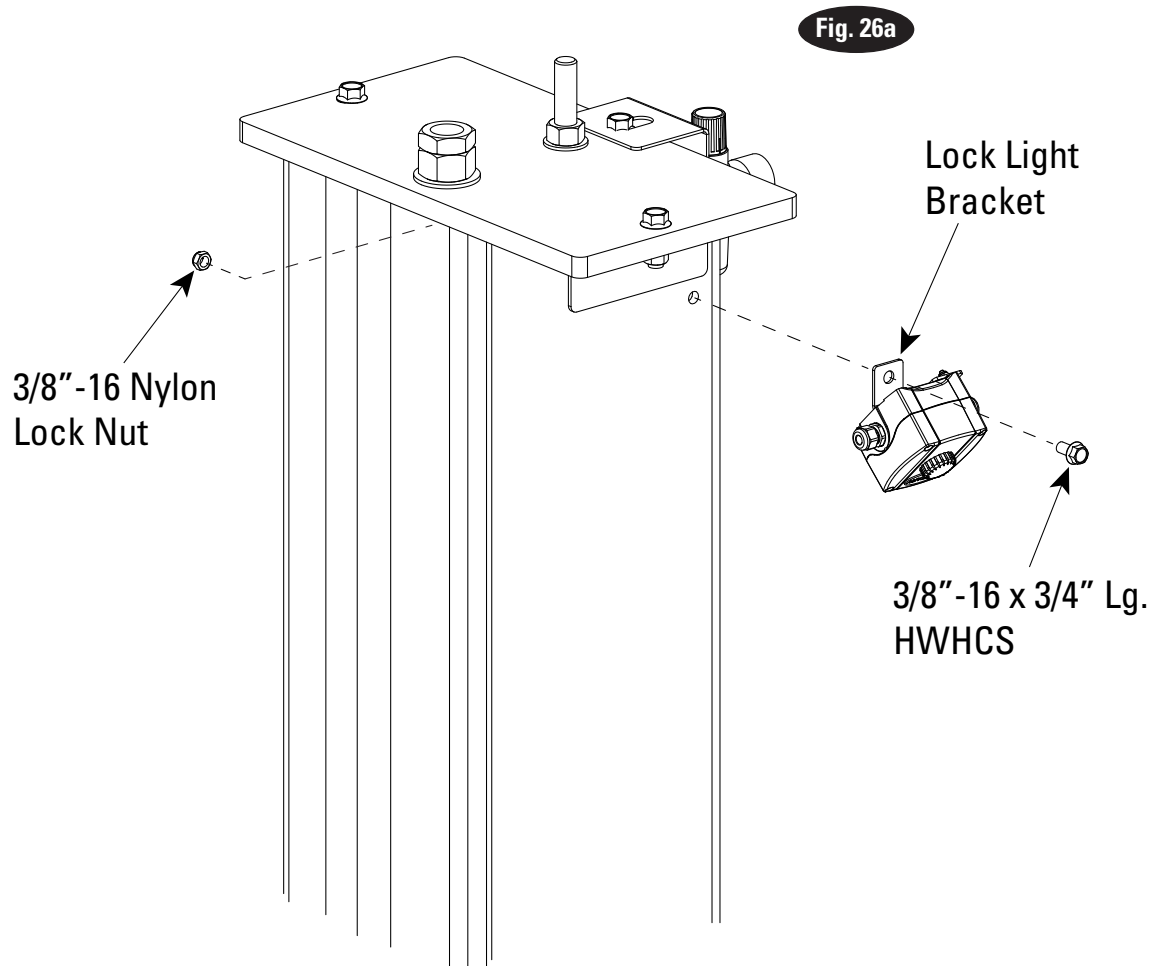
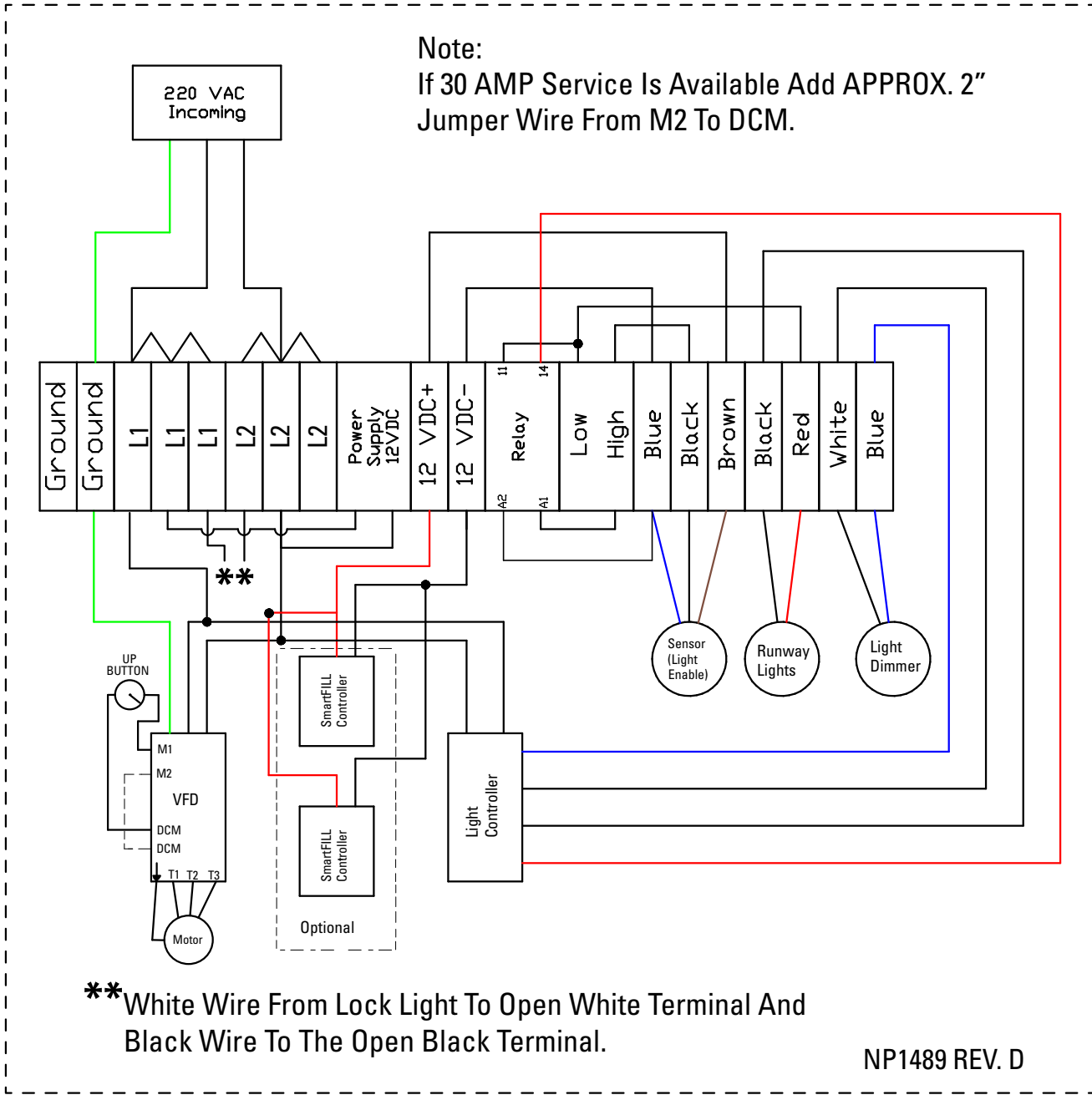

Fig. 26b

Note:
 If 30 AMP Service Is Available Add APPROX. 2"
 Jumper Wire From M2 To DCM.



**** White Wire From Lock Light To Open White Terminal And Black Wire To The Open Black Terminal.**

NP1489 REV. D

15. Air Line Connections:

Note: Locking latches require 100 psi. (689 kPa.) min. to 120 psi. (827 kPa.) max. air pressure.

IMPORTANT A filter/regulator/lubricator must be installed on air supply at lift. Failure to do so will void the warranty.

Note: Cut air line tubing with sharp blade to length as required. Tubing must be cut square with no burrs. To assemble air line tubing into fitting, use firm, manual pressure to push tubing into fitting until it bottoms, Fig. 27. If removal of the air line tubing from the fitting is ever required, hold Push Sleeve in (against fitting) and, at the same time, pull out on tubing.

A. Lift should be at full height and lowered on latches.

- B. **FRL Installation:** Remove 1/2"-13NC HWHCS and 1/2"-13NC Hex Nut and place FRL Bracket as shown, Fig. 28.
- C. Attach FRL using M4 SHCS and M4 Hex Nylon Lock Nut, Fig. 28.
- D. Connect 3/8" air line from existing facility supply air to the FRL. Run 3/8" air line from FLR to Smart Fill Controller, Fig. 28.

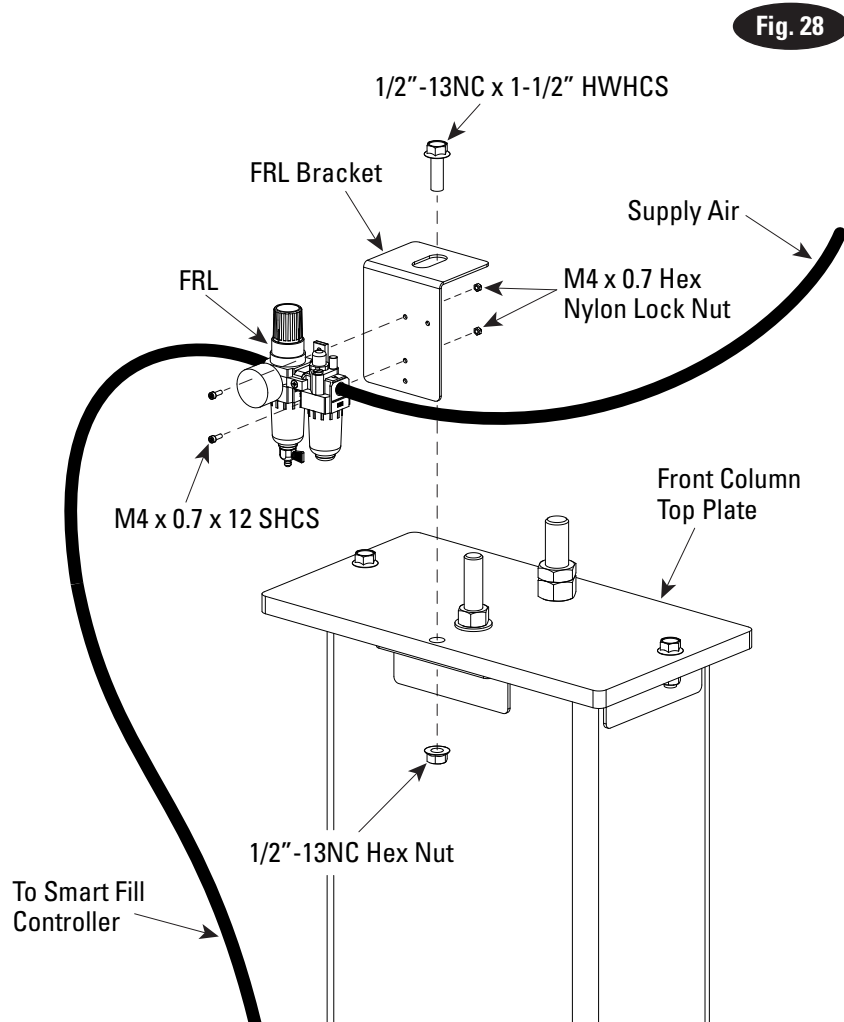
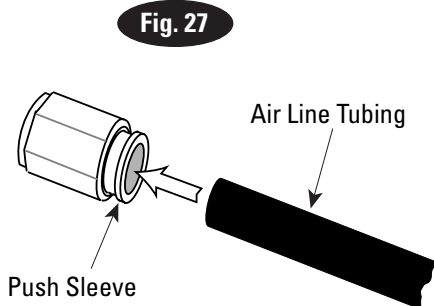

E. Airline Connections and Routing:

Place air lock valve bracket behind left hand side of motor using existing power unit attaching hardware.

F. Attach enclosed NP280 decal (ACTUATE TO RELEASE LATCHES) on bracket.

G. Run 1/4" airline from air lock valve to opening in runway. After passing through runway hole, attach "T", run 1/4" airline from one side of "T" to front L/H yoke air lock and 1/4" airline from the other side of "T" to the rear yoke.

The rear yoke air locks have been pre-plumbed so connect the new 1/4" airline just run from the "T" to the pre-plumbed yoke with a union fitting supplied in the air fitting bag. Repeat on opposite side of yoke, running 1/4" airline to R/H front yoke. Fig. 30.

- H. Check for air leaks by depressing air valve. Repair as required.
- I. Use provided cable ties to tie air line to hydraulic hose between power unit and lift.
- J. Actuate air valve and check latch operation on all four corners. The locking latches should pull in beyond yoke ends to clear the latch bars located in all four columns.
- K. Use cable ties provided to tie 3/8" air supply to electrical supply conduit at approximately 2'-0" (51mm) intervals.

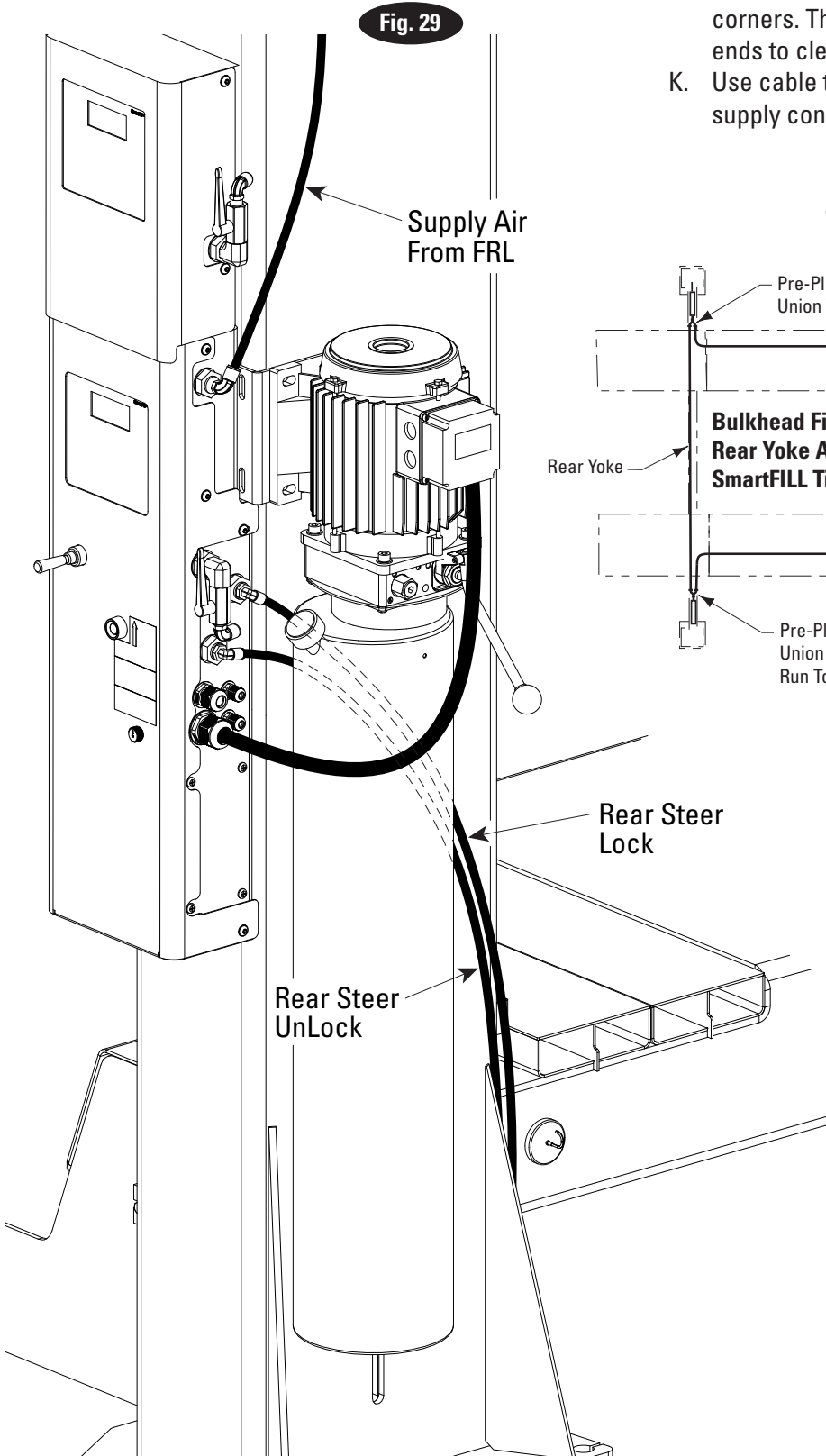

Fig. 29

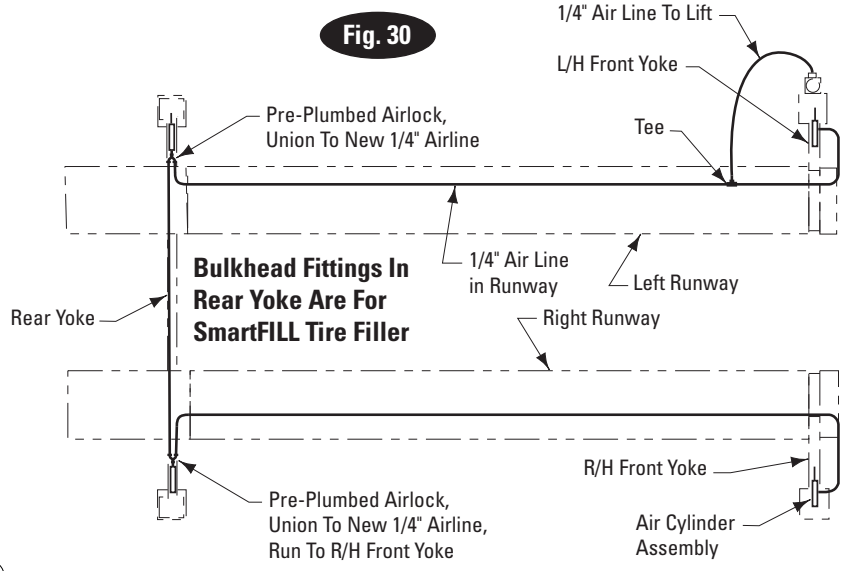
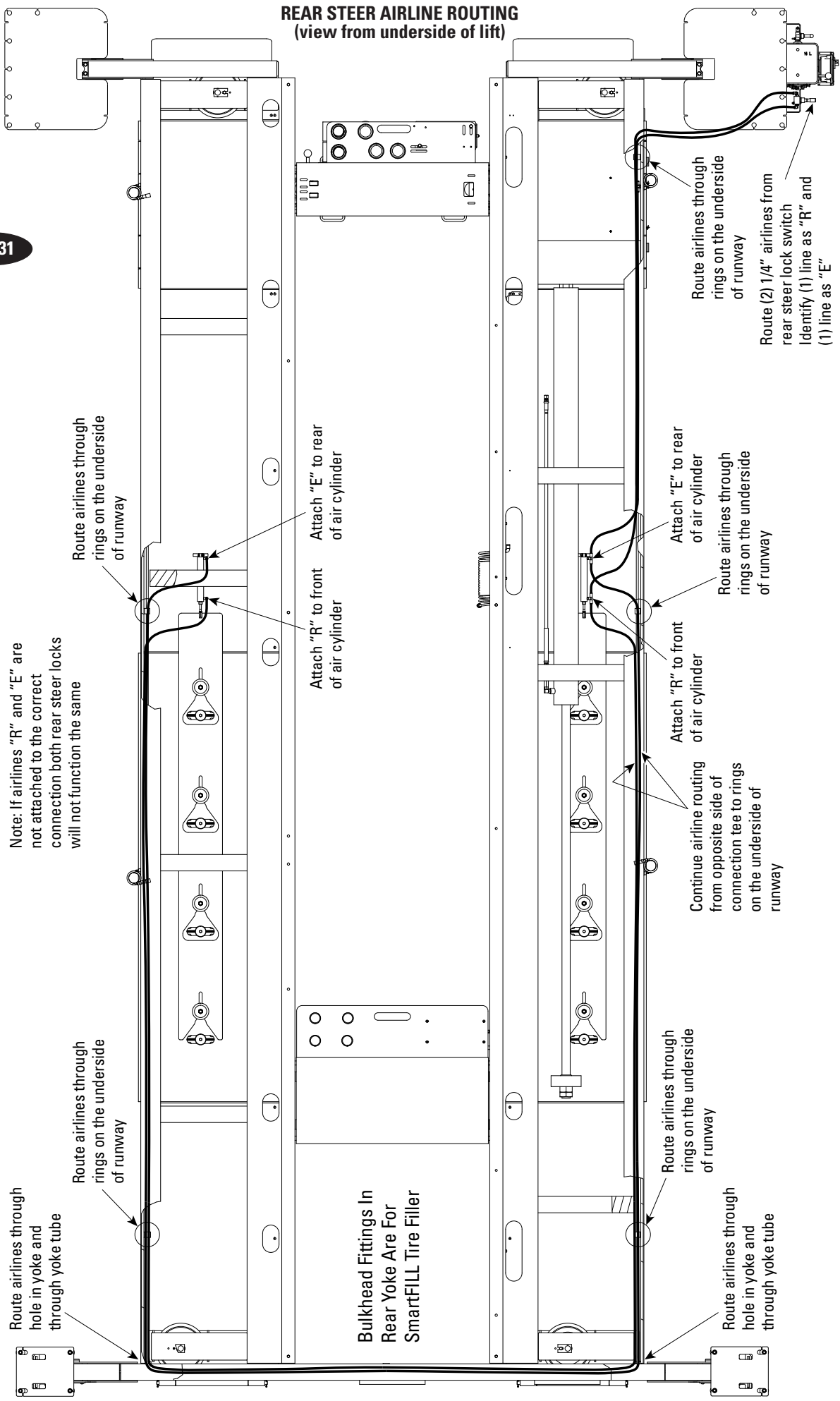

Fig. 30

Hoses and wires should be covered with split wire loom (S130469) after routing is complete. Attach and secure hoses and wires with supplied zip ties.

**REAR STEER AIRLINE ROUTING
(view from underside of lift)**

Fig. 31



Note: If airlines "R" and "E" are not attached to the correct connection both rear steer locks will not function the same

Route airlines through rings on the underside of runway
Route (2) 1/4" airlines from rear steer lock switch
Identify (1) line as "R" and (1) line as "E"

Bulkhead Fittings In Rear Yoke Are For SmartFILL Tire Filler

16. Oil Filling: Use Dexron III ATF, or hydraulic fluid that meets ISO 32 specifications. System capacity is 19-1/2 quarts or 18-1/2 liters. Use Dexron III ATF or equal. Fully lower lift. Remove fill/breather cap, Fig. 32. Fill to minimum fill line on tank, replace cap.

Note: If fill/breather cap is lost or broken, order replacement, Fig. 32.

17. Bleeding: Lift must be fully lowered before changing or adding fluid. Raise and lower lift six times. The cylinder is self-bleeding. After bleeding system, fluid level in power unit reservoir may be down. Add more ATF or ISO32 hydraulic oil, if necessary, following instructions in Step 19. To pressure test, run lift to full rise and run motor for approximately 5 seconds. Stop and check all fittings and hose connections. Tighten or reseal if required. Lower lift. If fill/breather cap, Fig. 32, is lost or broken, order replacement.

Note: Some test fluid may be spilled from the cylinder breather vent during bleeding of the system.

18. Assemble wheel stop on front of runway using 1/4"-20NC 2-3/4" Lg. HHCS. Assemble ramp assembly using hinge pin and cotter pin on rear of runway, Fig. 33.

Fig. 32

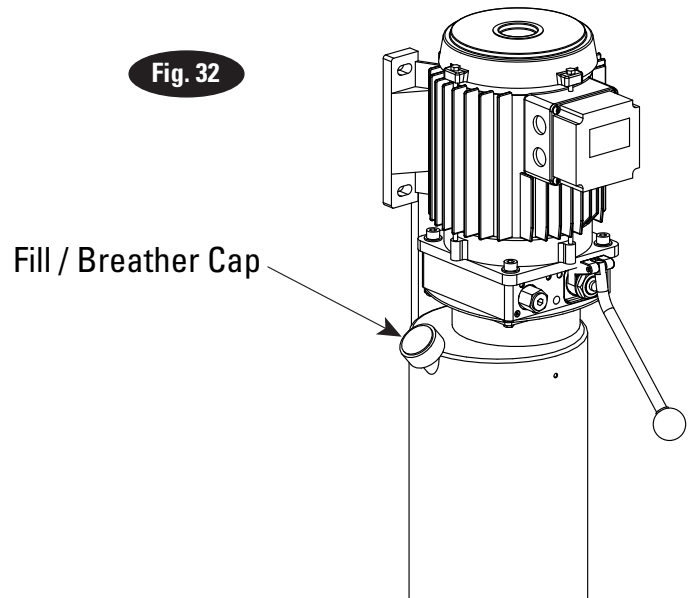
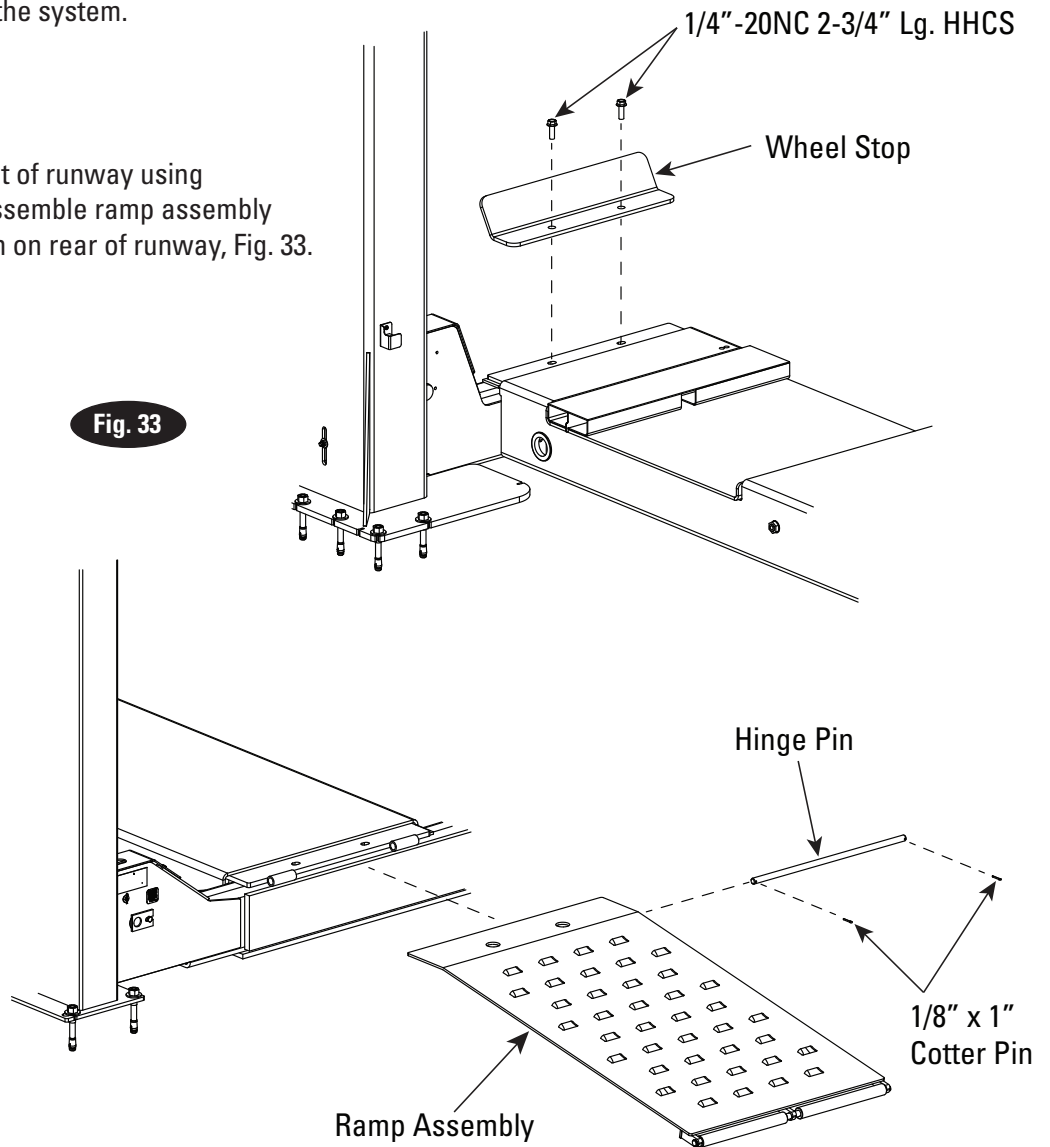

Fig. 33



19. Final Adjustments:

A. Load vehicle such as 3/4 ton truck or van onto lift.

B. Cable Adjustment:

1. Slowly jog the power unit, allowing two seconds between jogs, until a latch or latches are heard engaging. Check all corners to see which latch(es) have engaged. The corner(s) that are engaged will not be adjusted. Proceed to one of the corners that has not engaged and loosen the cable jam nut. Turn the cable adjustment nut clockwise, holding the cable with the square end of the threaded portion under the top plate, Fig. 34, until you hear the latch engage, then stop. Lock down the adjustment nut with the jam nut.
2. Proceed to the other corners until all latches have clicked into locking position.
3. Raise and lower lift to check for lock engaging sequence. The sound of lock engagement should sound simultaneously, the front cables may click slightly before the rear to compensate for the loaded condition.

CAUTION If you run out of the square holding area on the cable under the top plate, grip the top threaded portion with Locking Pliers to tighten. If the nut bottoms out or is close to bottoming out on the cable adjustment thread, then all the cables, sheaves and pins should be replaced. See 4-Post Inspection and Maintenance Guide and check for broken cable strands if you must grip the top threaded portion with Locking Pliers. If a broken cable is detected, ALL the cables, sheaves, and pins should be replaced before lift is put into operation.

CAUTION When making changes to adjustment nuts on cable end always leave at least two threads showing between nut and end.

Note: Latches may not click in at the same time when vehicle is being raised. They should be close. Be sure all four corners have passed the locking latch bar slot before lowering lift on locking latches.

Note: All bolts and nuts mentioned in this booklet are grade 5 unless otherwise stated.

Note: Cotter pins are usually good for one time use only. Replace any cotter pin, if removed, with a new cotter pin.

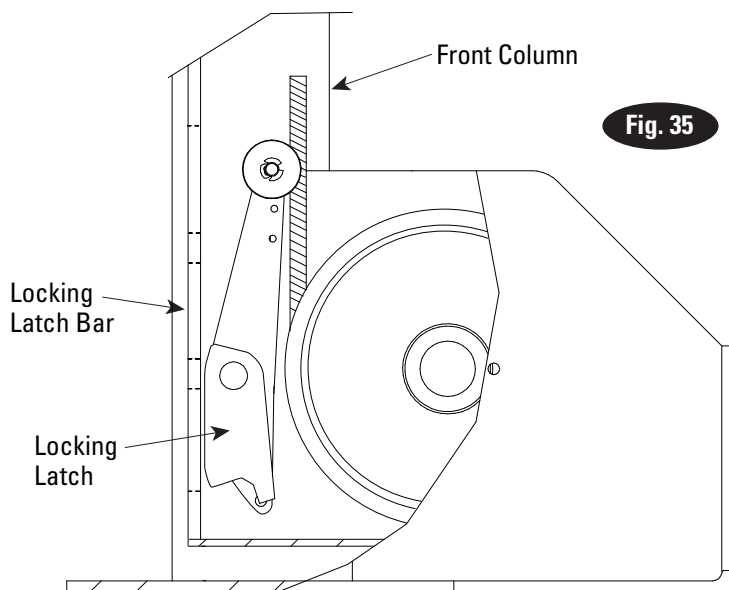
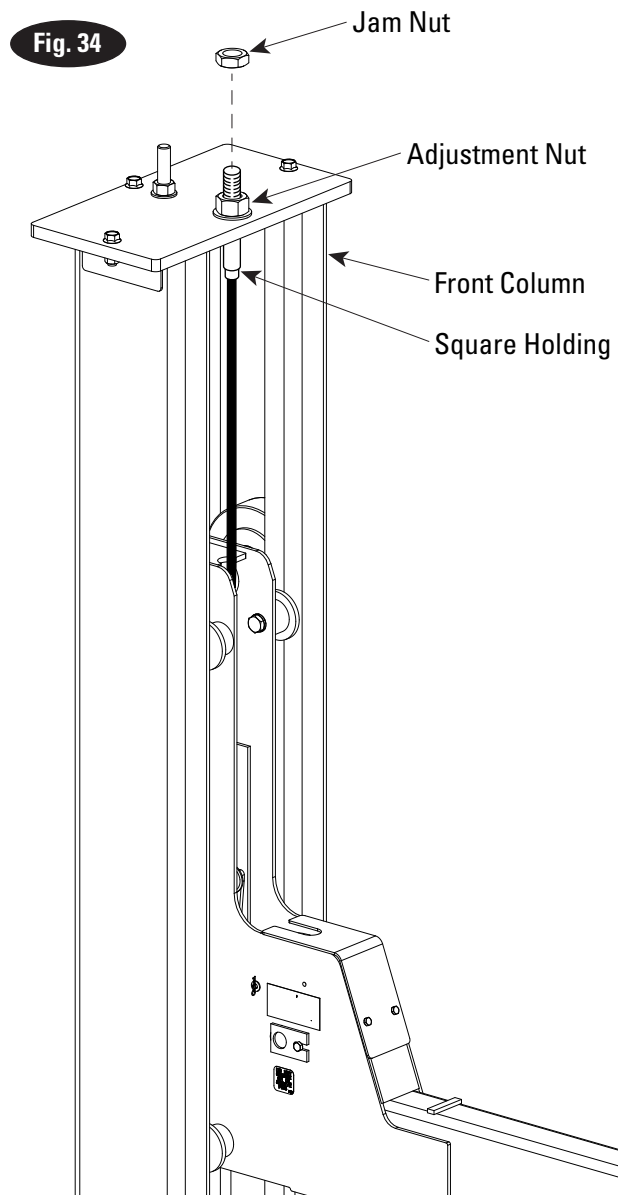

20. Rolling Jack:

- A. Adjust rolling jack telescoping ends until roller rests on runway track, Fig. 36. Make sure wheels are on tracks and center rolling jack between runway on end sections.
- B. Place jack on runway track at front and rear with air pump facing ends of runways.
- C. Recommended operating pressure is 100-120 PSI. (689-827 kPa).
- D. Attach rubber stops see Fig. 36.

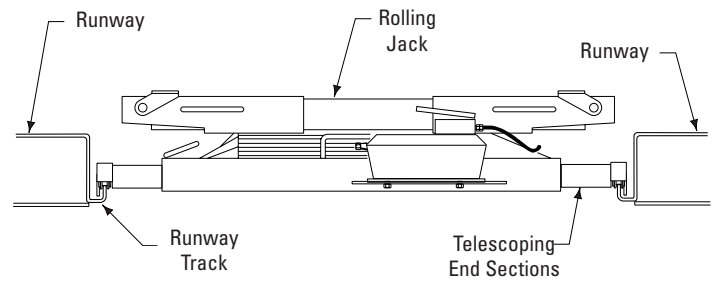
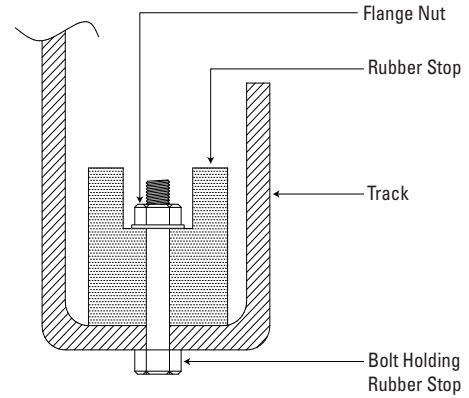

Fig. 36



Attach rubber bridge stops to 9.5mm holes 14" (356mm) off center of runways. Insert 1/4-20 bolt up through runway and stop. Attach 1/4-20 and 1/4 flat washer to top of stop.

21. Air Line Routing: See Fig. 37.

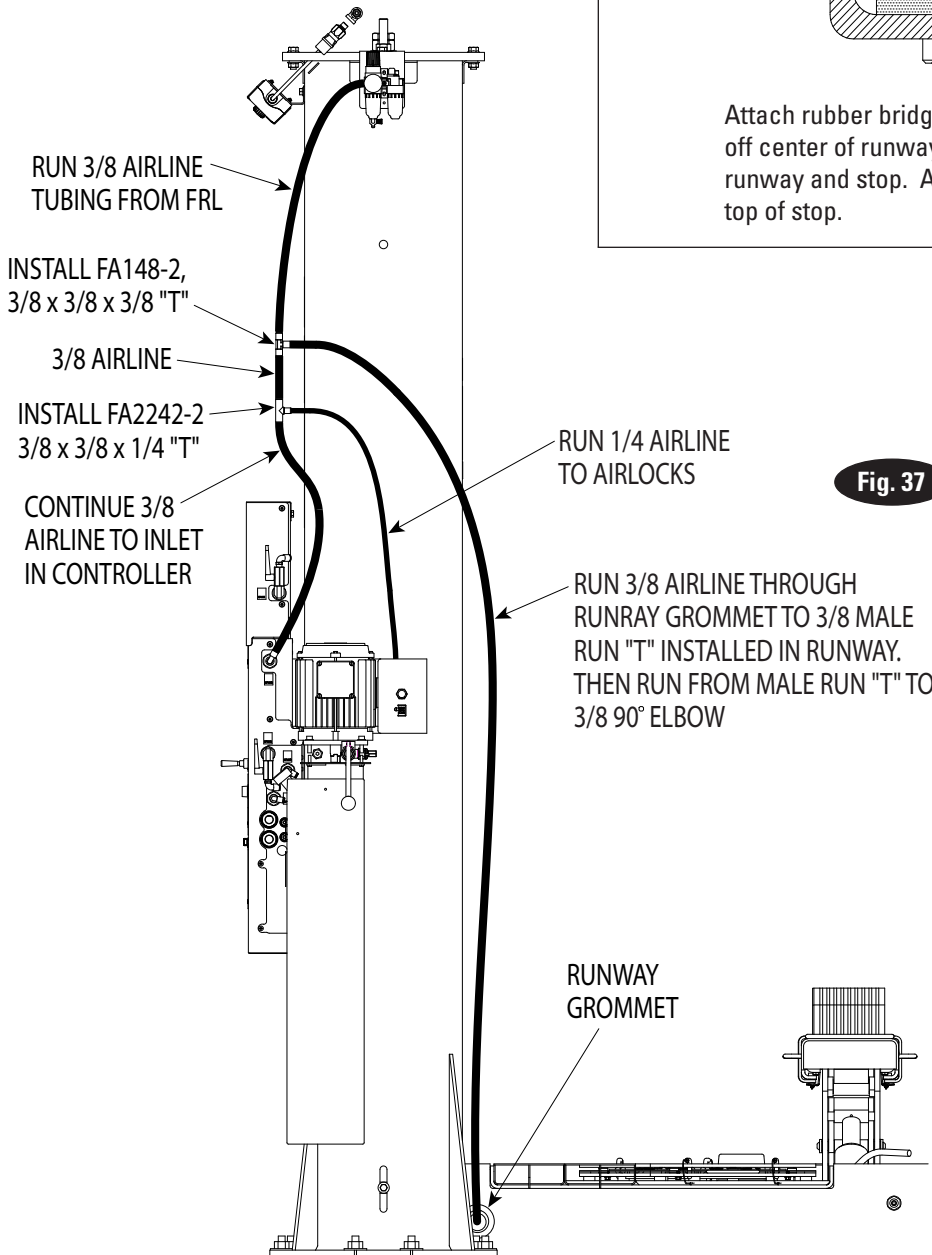

Fig. 37

22. Internal Air Line: This lift is equipped with an internal airline that provides air to both rolling jacks and extra access point for air driven tools (Quick Disconnect Coupler), Fig. 37a. All internal air lines are factory assembled.

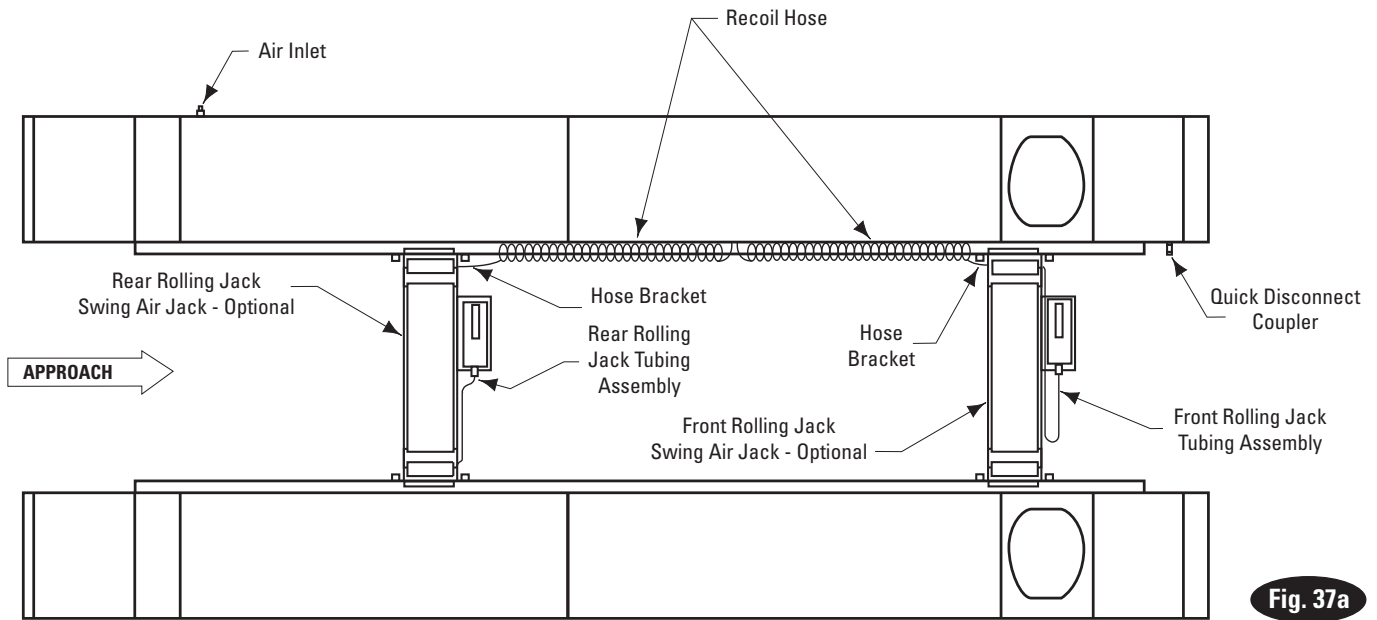
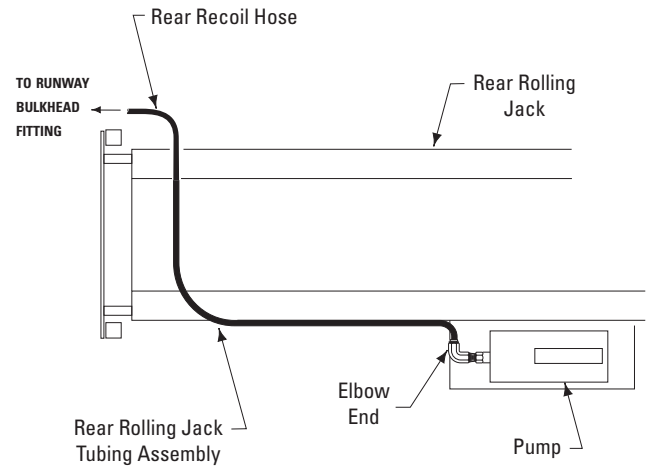

Fig. 37a

23. Rear Recoil Hose Installation:

- A. Assemble retainer cable. Insert retainer cable through coils of recoil hose, Fig. 41. Connect one end of recoil hose to coupling welded on rolling jack, Fig. 40.
- B. Connect other end of front recoil hose to bulkhead T-fitting in center of runway.
- C. Connect elbow end of rolling jack tubing assembly to air pump, and male end to the coupling, Fig. 40.

Note: Cut air line tubing with sharp blade to length as required. Tubing must be cut square with no burrs. To assemble air line tubing into fitting, use firm, manual pressure to push tubing into fitting until it bottoms, (see below). If removal of the air line tubing from the fitting is ever required, hold Push Sleeve in (against fitting) and, at the same time, pull out on tubing.



CONNECT TO REAR RECOIL HOSE

Fig. 38

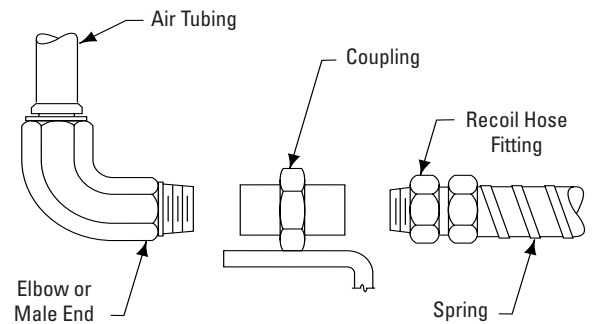
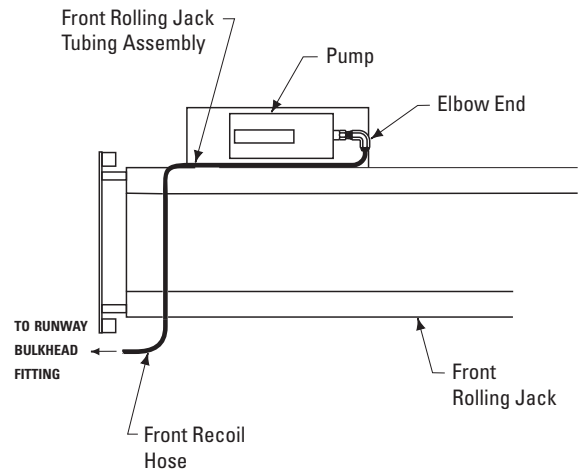

Fig. 39



CONNECT TO FRONT RECOIL HOSE

Fig. 40

24. Front Recoil Hose Installation:

- A. Assemble retainer cable. Insert retainer cable through coils of recoil hose, Fig. 41. Connect one end of recoil hose to coupling welded on rolling jack, Fig. 40.
- B. Connect other end of front recoil hose to bulkhead T-fitting in center of runway.
- C. Connect elbow end of rolling jack tubing assembly to air pump, and male end to the coupling, Fig. 40.

Note: Cut air line tubing with sharp blade to length as required. Tubing must be cut square with no burrs. To assemble air line tubing into fitting, use firm, manual pressure to push tubing into fitting until it bottoms, (see below). If removal of the air line tubing from the fitting is ever required, hold Push Sleeve in (against fitting) and, at the same time, pull out on tubing, Fig. 42.

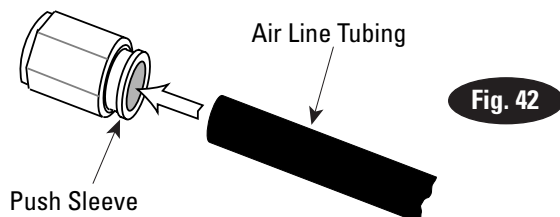

Fig. 42

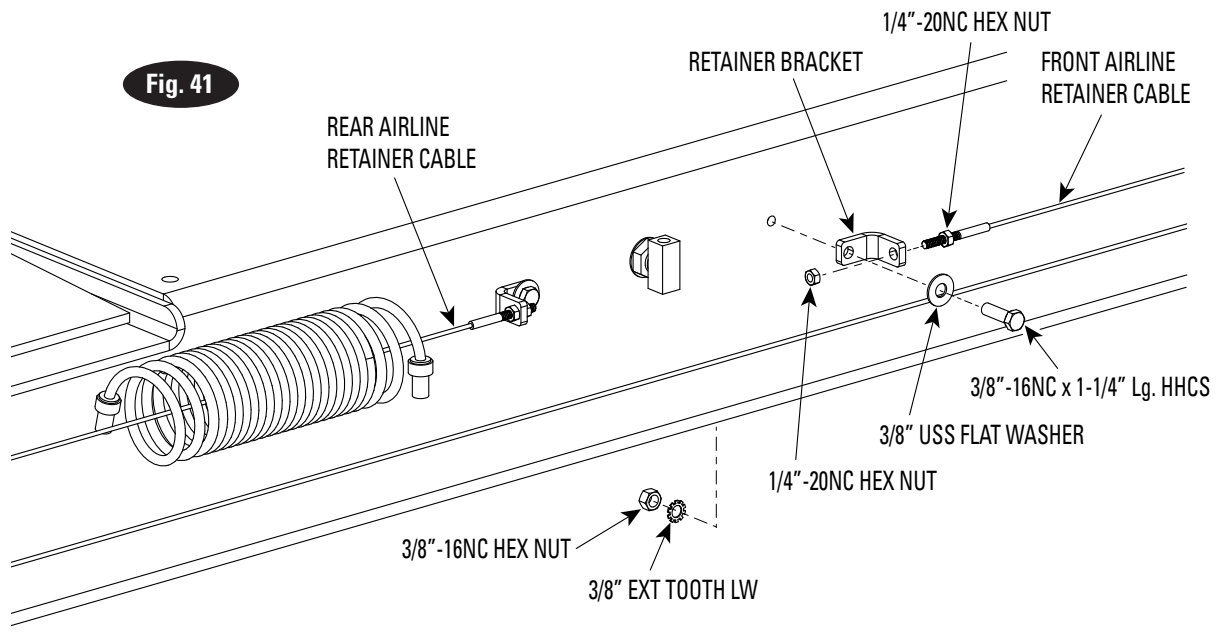

Fig. 41

25. Radius Gauges:

- A. Place the radius gauges in the recesses of both runways. Use radius gauge spacers as necessary, Fig. 43.

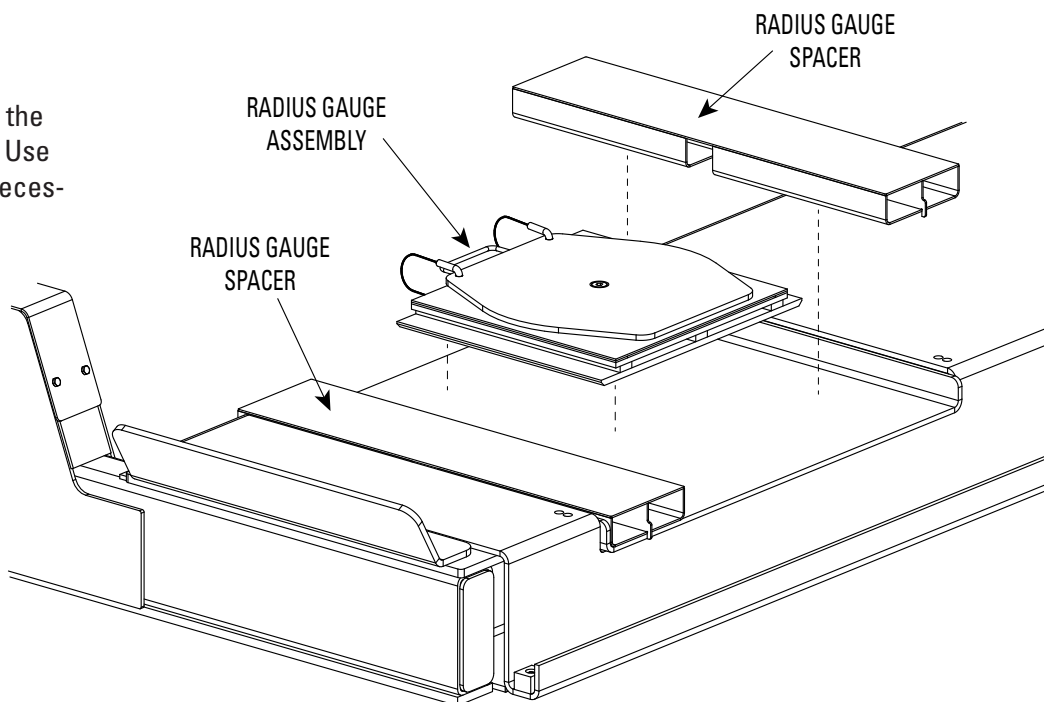

Fig. 43

26. Runway Leveling Adjustments:

- A. Engineer's automatic level (transit):
 - 1. Locate the Level, at a convenient location in the shop that allows an unobstructed view of all four corners of the Lift's runways.
 - 2. Follow the Level manufacturer's instructions for proper setup of the Level. Be sure it is adjusted level in all directions.
 - 3. Readjust Level if tripod or Level is bumped or disturbed.
- B. Raise lift approximately 28"- 32" (711-813mm), then lower lift until all locking latches are engaged in each column and the runways are in full down position on locks.
- C. Place the Level target on the right/front wheel turning radius gauge.
- D. Beginning with "A" position, Fig. 44, sight the Level to the target and mark the number or the graduation on the inch scale of the target that aligns to the crosshairs of the Level, Fig. 45.

Note: Use a pencil, marking pen or attach a paper clip onto the target scale at the crosshair reference.

- E. Next, move the target and place it on the turning radius gauge at point "B", Fig. 44.
- F. Rotate the Level and focus on the target scale.
- G. Adjust the latch bar adjustment nut at the top of the column at "B", Fig. 44, by loosening the jam nut and turning adjustment nut, Fig. 46, until the crosshairs of Level align to reference mark on the target scale.
- H. Repeat steps E., F. and G., locating the target assembly at points "C" and "D" and adjusting the latch bar at each corresponding column until the reference mark on the target scale is on the crosshairs of the Level.

Note: Runways Must Be Level Side To Side, Maximum Tolerance Front To Rear 1/16" (1.6mm).

- I. Always recheck the level of the runways to be sure all four latch bars are adjusted correctly. Start at point "A" and recheck level at points "B", "C", and "D", Fig. 44. Readjust as needed. The runways are now level at all four points.
- J. To complete the leveling procedures, lock each latch bar jam nut tightly against bottom of column top plate, Fig. 46. Finally, tighten 3/8"-16NC x 1-3/4" Lg. bolt and 3/8"-16NC hex flanged WZ lock nut on front latch bar bases, ref Fig. 13.

Fig. 44

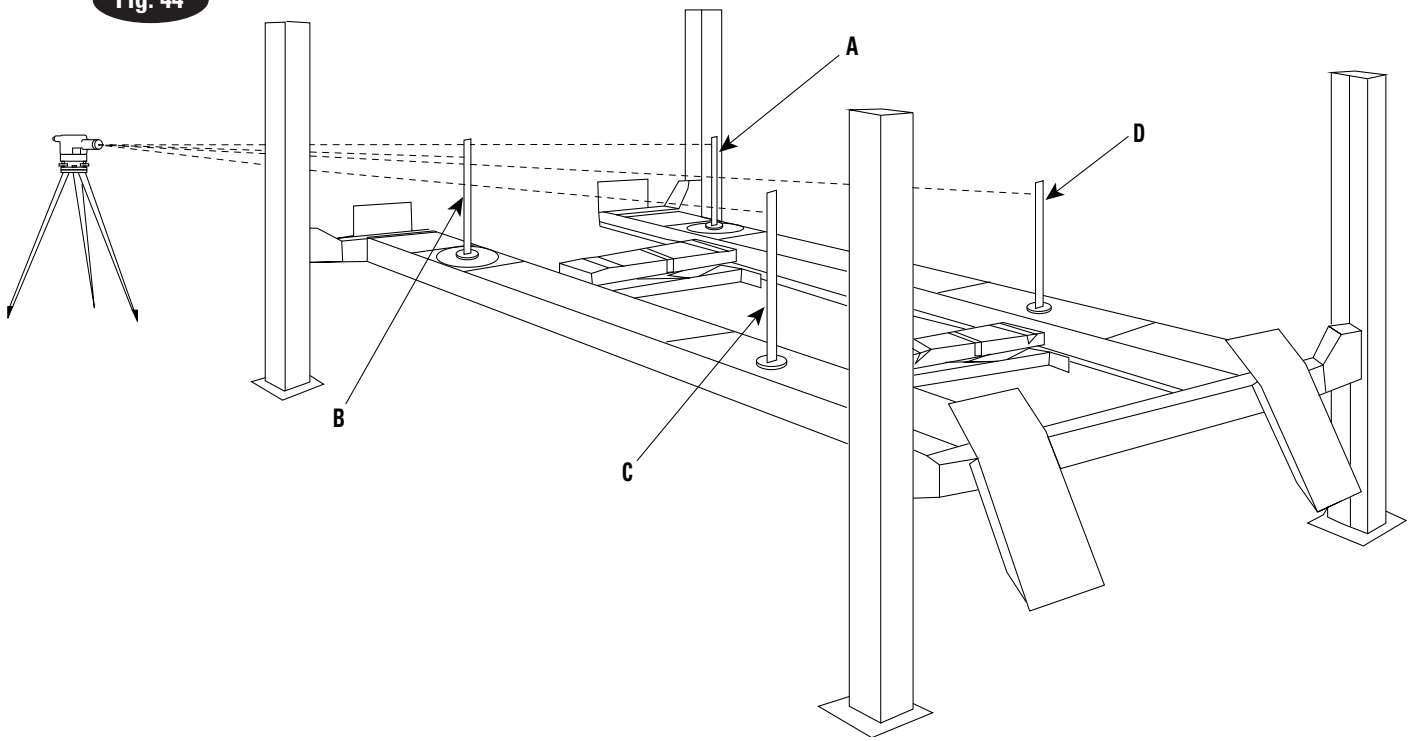

Fig. 45

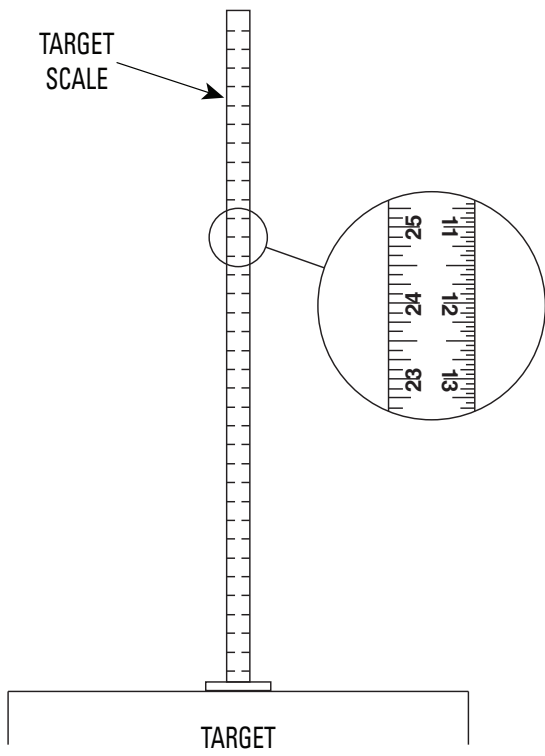
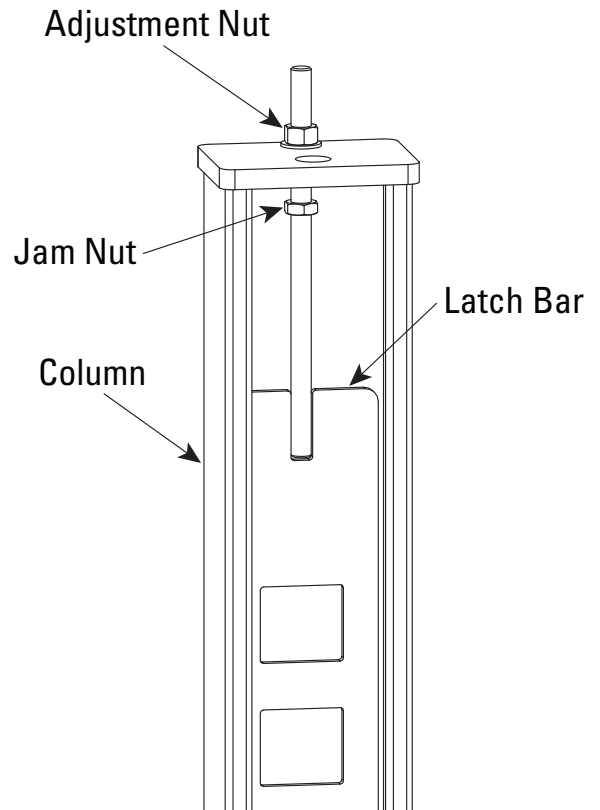

Fig. 46



ATTENTION INSTALLER:

Please return this booklet to literature package and give to lift owner/operator.

Trained Operators and Regular Maintenance Ensures
Satisfactory Performance of Your Rotary Lift.

Contact Your Nearest Authorized Rotary Parts Distributor for Genuine Rotary Replacement Parts. See
Literature Package for Parts Breakdown.



Rotary World Headquarters
3005 Highland Parkway, Suite 200
Downers Grove, Illinois 60515, USA
www.vsgdover.com
800.640.5438

North / South America Contact Information

Sales:

1.812.273.1622 / 800.445.5438
insidesales@vsgdover.com

Tech. Support:

800.445.5438
technicalsupport@rotarylif.com

Government Sales:

800.445.5438 X5655
rotarylif.com/Government-Purchasing-Assistance/

Additional information at rotarylif.com

Global Contact Information

Australasia: +60.3.5192.5910
Brazil: +55.11.4534.1995
Canada: 1.905.812.9920
European Headquarters/Germany: +49.771.9233.0
Latin America/Caribbean: 1.812.273.1622
Middle East/Northern Africa: +49.771.9233.0
Southern Africa: 1.812.273.1622
United Kingdom: +44.178.747.7711

